

Spectral Localization by Gaussian Random Potentials in Multi-Dimensional Continuous Space

Werner Fischer,^{1,2} Hajo Leschke,¹ and Peter Müller³

Received January 13, 2000; final June 28, 2000

A detailed mathematical proof is given that the energy spectrum of a non-relativistic quantum particle in multi-dimensional Euclidean space under the influence of suitable random potentials has almost surely a pure-point component. The result applies in particular to a certain class of zero-mean Gaussian random potentials, which are homogeneous with respect to Euclidean translations. More precisely, for these Gaussian random potentials the spectrum is almost surely only pure point at sufficiently negative energies or, at negative energies, for sufficiently weak disorder. The proof is based on a fixed-energy multi-scale analysis which allows for different random potentials on different length scales.

KEY WORDS: Random Schrödinger operators; Anderson localization.

1. INTRODUCTION

Even more than 40 years after Anderson's pioneering paper [An], single-particle Schrödinger operators with random potentials continue to play a prominent rôle for understanding the suppression of charge transport in disordered solids by electronic localization. In this context both spectral and dynamical criteria for localization are commonly studied. Spectral localization means that there is only (dense) pure-point spectrum in certain energy regimes. In addition, the corresponding eigenfunctions are often required to decay exponentially at infinity. As to criteria for dynamical

Dedicated to the memory of Uwe Brandt (15 April 1944–1 November 1997).

¹ Institut für Theoretische Physik, Universität Erlangen-Nürnberg, Staudtstraße 7, D-91058 Erlangen, Germany; e-mail: leschke@theorie1.physik.uni-erlangen.de

² New address: Infineon Technologies, P.O. Box 800949, D-81609 München, Germany.

³ Institut für Theoretische Physik, Georg-August-Universität, D-37073 Göttingen, Germany; e-mail: Peter.Mueller@Physik.Uni-Goettingen.DE

localization, we mention a sufficiently slow long-time growth of the spreading of quantum states or the vanishing of the direct-current conductivity of the corresponding ideal Fermi gas at zero temperature; see [FS, MH, GB, AG, BFM, DS] for works along these lines. Yet, the interrelations between the different criteria are not understood in sufficient generality and are presently under active debate [Si, RJLS, La, BCM, KL].

The goal of this paper is to contribute to the understanding of spectral localization for random Schrödinger operators in multi-dimensional Euclidean space \mathbb{R}^d . Using physical units in which the mass of the particle, its electric charge and Planck's constant divided by 2π are all equal to one, these operators are informally given by differential expressions of the form

$$H(V) = \frac{1}{2}(i\nabla + a)^2 + V \quad (1.1)$$

Here, $i = \sqrt{-1}$ is the imaginary unit and ∇ is the nabla operator. The non-random vector potential a allows for the presence of a magnetic field $\nabla \times a$, and the scalar potential V is an ergodic random field. We are primarily interested in a constant magnetic field and a zero-mean Gaussian random potential V . Under certain assumptions on the covariance function of V we will show that the spectrum of $H(V)$ is almost surely only pure point at sufficiently negative energies or, at negative energies, for sufficiently weak disorder, see Theorem 2.12 below. In the physics literature such a result has been inferred from non-rigorous arguments several decades ago and is nowadays usually taken for granted. These arguments rely on the idea that at sufficiently low energies even weak disorder should be able to suppress quantum-mechanical tunnelling. Our point here is to present a complete and detailed mathematical proof.

The first mathematical proof of spectral localization for arbitrary space dimensions $d \geq 1$ dates back to [FS], who considered Anderson's original model on the simple cubic lattice \mathbb{Z}^d . Their method of proof is a so-called multi-scale analysis, where elements from Kolmogorov–Arnold–Moser theory are invoked for coping with small denominators in order to bound resolvents of finite-volume random Schrödinger operators with high probabilities. Consequences of this method were elaborated on in [MS1, DLS, FMSS, SW]. Using scaling ideas borrowed from percolation theory, a substantial simplification and streamlining of the multi-scale analysis is due to [Sp2, DK1]. Another breakthrough in proving spectral localization for lattice models was [AM] where a completely different, technically much less involved proof was presented; see also [Ai, Gra, Hu, AG, DMP3, ASFH] for subsequent works along these lines. In contrast to the multi-scale analysis the method of [AM] does not seem to be adaptable to general continuum models as (1.1).

Notably, the first proof [MH] of spectral localization for a random Schrödinger operator in multi-dimensional continuous space \mathbb{R}^d appeared shortly after [FS]. Yet, it took ten more years until these investigations were continued in [CH1], a paper which opened the field for a deeper understanding of Schrödinger operators with random alloy-type potentials in multi-dimensional continuous space. Spectral localization is now known to occur near the band edges of the spectrum of randomly perturbed periodic Schrödinger operators [K11, BCH2, KSS2, KSS1, V, St] and near the band edges of disorder-broadened Landau levels arising from operators of the form (1.1) [CH2, BCH1, W, DMP3]. Additional results are available when restricting the latter onto the eigenspace of a single Landau level [DMP1, DMP2, PS1, PS2]. In [K12] spectral localization is established near the bottom of the spectrum, but without an otherwise frequently used positivity assumption on the single-site potential, see also [BS] for similar results for one dimension. Models with random point interactions allow for more specific methods in order to prove spectral localization [BG, DMP3, PS2]. Good overviews of the mathematical theory related to Anderson localization can be found in the survey articles [Sp1, MS2, Ki1] and the monographs [CL, PF, St].

To our knowledge, proofs of spectral localization in multi-dimensional continuous space \mathbb{R}^d have so far been completed only for alloy-type random potentials and related ones. Basically, these potentials still have an underlying lattice structure and, in some works [KSS2, Z, St], were allowed to exhibit correlations via a long-range tail of the single-site potential. In contrast, the methods developed in this paper are tailored for a wide class of truly continuum random potentials in multi-dimensional continuous space, which—as is the case for Gaussian random potentials—may have unbounded fluctuations and genuine long-range correlations. Besides mathematical challenges, the motivation for coping with these additional difficulties stems from the fact that Gaussian random potentials are appealing for at least three reasons. First, there is a belief in the “normality of the normal distribution” in nature. Second, the n -point cumulant functions of Gaussian random potentials vanish for all $n \geq 3$, a fact which leads to computational simplifications. Third, the degree of randomness can be varied by choosing different covariance functions, that is, 2-point cumulant functions. For all three reasons Gaussian random potentials find widespread applications in—if not dominate—the corresponding physics literature, see for example the books [BEEK+, SE, LGP, E] and references therein.

Due to the long-range correlations of Gaussian random potentials we were not able to perform a “variable-energy” multi-scale analysis in the spirit of [Sp2, DK1] in order to prove localization. Instead we build on

the “fixed-energy” multi-scale analysis of [DK2], which guarantees that all events, whose joint probability has to be estimated, are far enough apart. As a consequence, we obtain only algebraic (and not exponential) decay estimates. The necessary techniques for coping with continuum Schrödinger operators are patterned after [CH1]. We also refer to the remarks at the beginning of Section 3 for a brief description of the multi-scale analysis used in this paper.

Part of the localization result, whose proof is presented here in full detail, was announced in [FLM] and [FHLM1]. Its key ideas and the way in which the assumptions on the Gaussian random potential enter were briefly outlined in [FLM], as far as the absence of the absolutely continuous spectrum is concerned. An important ingredient of the proof, a so-called Wegner estimate for Schrödinger operators with Gaussian random potentials, was formulated and proven in [FHLM2]. It is the purpose of this paper to provide the remaining details for a complete proof of the absence of both the absolutely continuous and the singular continuous spectrum. One reason why we have decided to give a rather explicit exposition is that our proof of spectral localization requires stronger assumptions on the Gaussian random potential than those being sufficient for obtaining the Wegner estimate. Another reason is that Stollmann’s forthcoming book [St]—the only source we are aware of which provides a detailed multi-scale analysis for continuum models with long-range correlated random potentials—does not cover the type of random potentials considered here.

The plan of the paper is as follows. Section 2 serves to fix the basic notation and to give a precise definition of the random Schrödinger operators we are interested in. In Theorem 2.12 of Subsection 2.2 we state our localization result for Schrödinger operators with Gaussian random potentials. In Subsection 2.3 we recall the Wegner estimate from [FHLM2]. The multi-scale analysis is presented in detail in Section 3. All results of Sections 3 and 4 are formulated and proven for a rather general class of truly continuum correlated random potentials, which includes Gaussian ones. The main technical result of the multi-scale analysis, resolvent estimates on multiple length scales, is formulated in Subsection 3.2 as Theorem 3.14. The transition to the infinite-volume resolvent is performed in Subsection 3.3. In Section 4 we show how to build on the results from Section 3 in order to conclude that the spectrum is only pure point in certain energy regimes. Section 5 is devoted to the proof of the main Theorem 2.12 for Gaussian random potentials. This is done by verifying that the more general theorems of Sections 3 and 4 can be applied. In the Appendix we present a simple explicit Combes–Thomas type of estimate needed in Subsection 5.2.

2. BASIC DEFINITIONS AND MAIN RESULT

In Subsection 2.1 we fix our notation, give a precise definition of random Schrödinger operators and compile some basic facts. Our main result is stated in Subsection 2.2. Finally, we recall a Wegner estimate in Subsection 2.3.

2.1. Random Schrödinger Operators

As usual, let $\mathbb{N} := \{1, 2, 3, \dots\}$ denote the set of natural numbers and $\mathbb{N}_0 := \mathbb{N} \cup \{0\}$. Let \mathbb{R} , respectively \mathbb{C} , denote the field of real, respectively complex, numbers and set $\mathbb{R}^+ := \{r \in \mathbb{R} : r > 0\}$ and $\mathbb{R}_0^+ := \mathbb{R}^+ \cup \{0\}$. An open cube A in d -dimensional Euclidean space \mathbb{R}^d , $d \in \mathbb{N}$, is the d -fold Cartesian product $A := I \times \dots \times I$ of an open interval $I \subseteq \mathbb{R}$, and ∂A stands for the boundary of A . The open cube with edges of length $l > 0$ and centre $x \in \mathbb{R}^d$ is the set $A_l(x) := \{y \in \mathbb{R}^d : |x - y|_\infty < l/2\}$. Here $|x|_\infty := \max_{j=1, \dots, d} |x_j|$ denotes the maximum norm of $x = (x_1, \dots, x_d) \in \mathbb{R}^d$. The Euclidean scalar product $x \cdot y := \sum_{j=1}^d x_j y_j$ of $x, y \in \mathbb{R}^d$ induces the Euclidean norm $|x| := (x \cdot x)^{1/2}$ of $x \in \mathbb{R}^d$. We also write $x^2 := x \cdot x$. The distance of two subsets $A, A' \subseteq \mathbb{R}^d$ with respect to the Euclidean (maximum) norm is defined as $\text{dist}_{(\infty)}(A, A') := \inf\{|x - y|_{(\infty)} : x \in A, y \in A'\}$.

Given a Borel subset $A \subseteq \mathbb{R}^d$ we denote its volume with respect to the d -dimensional Lebesgue measure as $|A| := \int_A d^d x$. The Banach space $L^p(A)$ consists of the Borel measurable complex-valued functions $\varphi: \mathbb{R}^d \rightarrow \mathbb{C}$ which are identified if their values differ only on a set of Lebesgue measure zero and possess a finite norm

$$\|\varphi\|_{p; A} := \begin{cases} \left(\int_A d^d x |\varphi(x)|^p \right)^{1/p} & \text{if } p < \infty \\ \text{ess sup}_{x \in A} |\varphi(x)| & \text{if } p = \infty \end{cases} \quad (2.1)$$

We use the abbreviation $\|\varphi\|_p := \|\varphi\|_{p; A}$ if there is no ambiguity. For $\varphi \in L^2(A)$ we also use the notation $\|\varphi\| := \|\varphi\|_2$ and recall that $L^2(A)$ becomes a separable Hilbert space when equipped with the scalar product

$$\langle \varphi, \psi \rangle := \int_A d^d x (\varphi(x))^* \psi(x) \quad (2.2)$$

Here the star denotes complex conjugation. We write $\varphi \in L^p_{\text{loc}}(\mathbb{R}^d)$, if $\varphi \in L^p(A)$ for all $A \subset \mathbb{R}^d$ with finite volume. Finally, $\mathcal{C}^n(\mathbb{R}^d)$ stands for the

vector space of functions $\varphi: \mathbb{R}^d \rightarrow \mathbb{C}$ which are n times continuously differentiable and $\mathcal{C}_0^\infty(\mathbb{R}^d)$ for the vector space of functions $\varphi: \mathbb{R}^d \rightarrow \mathbb{C}$ which are arbitrarily often differentiable and have compact supports.

The norm of a bounded operator $A: L^2(A) \rightarrow L^2(A)$ is defined as $\|A\| := \sup\{\|A\varphi\| : \varphi \in L^2(A), \|\varphi\| = 1\}$. The d -dimensional gradient or nabla operator $\nabla := (\partial/\partial x_1, \dots, \partial/\partial x_d)$ gives rise to the self-adjoint negative Laplacian $-\Delta: \mathcal{D}(-\Delta) \ni \varphi \mapsto -\nabla^2\varphi$ with domain $\mathcal{D}(-\Delta) := \{\varphi \in L^2(\mathbb{R}^d) : \varphi, (\nabla\varphi)_1, \dots, (\nabla\varphi)_d \text{ are absolutely continuous on } \mathbb{R}^d \text{ and } \nabla^2\varphi \in L^2(\mathbb{R}^d)\}$. Given a bounded open cube $A \subset \mathbb{R}^d$, the self-adjoint negative Dirichlet Laplacian is the operator $-\Delta_A: \mathcal{D}(-\Delta_A) \ni \varphi \mapsto -\nabla^2\varphi$ with domain $\mathcal{D}(-\Delta_A) := \{\varphi \in L^2(A) : \varphi, (\nabla\varphi)_1, \dots, (\nabla\varphi)_d \text{ are absolutely continuous on } A, \nabla^2\varphi \in L^2(A) \text{ and } \varphi(x) = 0 \text{ for all } x \in \partial A\}$.

Definition 2.1. A random potential V on \mathbb{R}^d is an \mathbb{R}^d -homogeneous random field $V: \Omega \times \mathbb{R}^d \rightarrow \mathbb{R}, (\omega, x) \mapsto V^{(\omega)}(x)$, on a complete probability space $(\Omega, \mathcal{A}, \mathbb{P})$ which is jointly measurable with respect to the product of the sigma-algebra \mathcal{A} of event sets in Ω and the sigma-algebra \mathcal{B}^d of Borel sets in \mathbb{R}^d . Moreover, defining the constants $p(d) := 2$ for $d \leq 3$, respectively $p(d) > d/2$ for $d \geq 4$, we assume the existence of two reals $p_1 > p(d)$ and $p_2 > p_1 d/[2(p_1 - p(d))]$ such that

$$\mathbb{E}\{\|V\|_{p_1; A_1(0)}^{p_2}\} < \infty \tag{2.3}$$

Here, $\mathbb{E}\{\cdot\} := \int_\Omega d\mathbb{P}(\omega)(\cdot)$ is the expectation associated with the probability measure \mathbb{P} .

For later purpose we recall from [D] the following

Definition 2.2. Given a random potential V on \mathbb{R}^d and a Borel subset $A \subset \mathbb{R}^d$, let the local sigma-algebra $\mathcal{A}_V(A)$ be the sub-sigma-algebra of events generated by the set of random variables $\{V^{(\cdot)}(x) : x \in A\}$. The strong mixing coefficient of V is defined by

$$\alpha_V(L, G) := \sup\{\kappa_V(A, A') : A, A' \subset \mathbb{R}^d; \text{dist}_\infty(A, A') \geq L; |A|, |A'| \leq G\} \tag{2.4}$$

where $L, G > 0$ and $\kappa_V(A, A') := \sup\{|\mathbb{P}(A \cap A') - \mathbb{P}(A)\mathbb{P}(A')| : A \in \mathcal{A}_V(A), A' \in \mathcal{A}_V(A')\} \leq 1/4$ measures the stochastic dependence of the restrictions of V to A and A' , respectively.

Now we give the precise definition of random Schrödinger operators of type (1.1) and collect some of their basic properties in

Proposition 2.3. Let $a: \mathbb{R}^d \rightarrow \mathbb{R}^d$ be a non-random, continuously differentiable vector field with vanishing divergence, $\nabla \cdot a = 0$, and let V be a random potential on \mathbb{R}^d in the sense of Definition 2.1. Then,

(i) given a bounded open cube $A \subset \mathbb{R}^d$, the associated *finite-volume random Schrödinger operator* with Dirichlet boundary conditions

$$H_A(V^{(\omega)}) : \mathcal{D}(-\Delta_A) \ni \varphi \mapsto \frac{1}{2}(i\nabla + a)^2 \varphi + V^{(\omega)}\varphi \quad (2.5)$$

is self-adjoint on $L^2(A)$ and its spectrum is purely discrete for \mathbb{P} -almost all $\omega \in \Omega$. Therefore the *finite-volume integrated density of states*

$$N_A^{(\omega)}(E) := \left\{ \begin{array}{l} \text{number of eigenvalues of } H_A(V^{(\omega)}), \text{ counting} \\ \text{multiplicity, which are strictly smaller than } E \end{array} \right\} \quad (2.6)$$

associated with $H_A(V^{(\omega)})$ is well-defined for \mathbb{P} -almost all $\omega \in \Omega$.

(ii) the operator $\mathcal{C}_0^\infty(\mathbb{R}^d) \ni \varphi \mapsto \frac{1}{2}(i\nabla + a)^2 \varphi + V^{(\omega)}\varphi$ is essentially self-adjoint for \mathbb{P} -almost all $\omega \in \Omega$. Its self-adjoint closure $H(V^{(\omega)})$ on $L^2(\mathbb{R}^d)$ is called (*the infinite-volume*) *random Schrödinger operator*.

(iii) the mappings $\omega \mapsto H_A(V^{(\omega)})$ and $\omega \mapsto H(V^{(\omega)})$ are measurable. The same is true for the projection-valued spectral measures of H_A and H associated with the pure-point, the absolutely continuous and the singular continuous component in the Lebesgue decomposition of their spectra.

Remark 2.4. We will primarily be interested in spatially constant magnetic-field tensors $\partial a_j / \partial x_k - \partial a_k / \partial x_j$, $j, k = 1, \dots, d$, and have thus dispensed with formulating Proposition 2.3 under weaker assumptions on the vector potential a . The interested reader may consult e.g., [HS], [BHL2] and [HLMW]. Since the proof of Proposition 2.3 is a standard result for $a = 0$ [Kil, CL], we will mainly comment on the changes required for $a \neq 0$.

Proof of Proposition 2.3. (i) Since the bound (2.3) ensures $V^{(\omega)} \in L_{\text{loc}}^{p_1}(\mathbb{R}^d) \subseteq L_{\text{loc}}^{p(d)}(\mathbb{R}^d)$ for \mathbb{P} -almost all $\omega \in \Omega$, it follows that for these ω 's the operator $ia \cdot \nabla + a^2/2 + V^{(\omega)}$ is an operator perturbation of $-\Delta_A$ with relative operator bound zero. Self-adjointness of $H_A(V^{(\omega)})$ on $\mathcal{D}(-\Delta_A)$ is then guaranteed by the Kato–Rellich theorem. Since operator boundedness with bound zero implies form boundedness with bound zero, the discreteness of the spectrum of $H_A(V^{(\omega)})$ follows from that of $-\Delta_A$ and the min–max principle, see e.g., Section 7.2 in [Kil].

(ii) It is shown in the proof of Prop. V.3.2 in [CL] that (2.3) implies the \mathbb{P} -almost sure existence of a decomposition $V = V_1 + V_2$ with $V_1 \in L_{\text{unif, loc}}^{p(d)}(\mathbb{R}^d)$, $V_2 \in L_{\text{loc}}^2(\mathbb{R}^d)$ and $V_2(x) \geq -cx^2$ for Lebesgue-almost all $x \in \mathbb{R}^d$ with some constant $c > 0$. Here we say that a measurable function

$\varphi: \mathbb{R}^d \rightarrow \mathbb{C}$ belongs to the space $L^p_{\text{unif, loc}}(\mathbb{R}^d)$, if $\sup_{y \in \mathbb{R}^d} \|\varphi\|_{p; A_1(y)} < \infty$. The claim thus follows from Thm. 2.5 in [HS], since $L^p_{\text{unif, loc}}(\mathbb{R}^d)$ is a subset of both $L^2_{\text{loc}}(\mathbb{R}^d)$ and the Kato class over \mathbb{R}^d , see e.g., Prop. 4.3 in [AiS].

(iii) This is a consequence of the considerations in Section V.1 of [CL] and of a straightforward generalization to non-zero vector potentials a of Prop. V.3.1 in [CL]. ■

In the next proposition we recall some important properties of ergodic random Schrödinger operators. For assertion (i) to hold, it is essential that, as usual, the pure-point spectrum of an operator is defined as the closure of the set of its eigenvalues.

Proposition 2.5. In addition to the requirements of Proposition 2.3 assume that the vector potential a gives rise to a constant magnetic-field tensor and that V is ergodic with respect to translations in \mathbb{R}^d . Then

(i) The spectrum of $H(V)$, as well as its components in the Lebesgue decomposition—the pure-point spectrum, the absolutely continuous spectrum and the singular continuous spectrum—are \mathbb{P} -almost surely equal to non-random closed subsets of the real line \mathbb{R} .

(ii) If, in addition, $\mathbb{E}\{\exp[-tV(0)]\} < \infty$ for all $t > 0$, there exists a non-random left-continuous distribution function N on \mathbb{R} , called the (*infinite-volume*) *integrated density of states*, such that

$$N(E) = \lim_{A \uparrow \mathbb{R}^d} \frac{N_A^{(\omega)}(E)}{|A|} \tag{2.7}$$

More precisely, there is a set $\Omega_0 \in \mathcal{A}$ of full probability, $\mathbb{P}(\Omega_0) = 1$, such that (2.7) holds for all $\omega \in \Omega_0$ and for all $E \in \mathbb{R}$ except for the at most countably many discontinuity points of N .

(iii) If, in addition, $\mathbb{E}\{|V(0)|^r\} < \infty$ for some $r \geq r' + 1$, where r' is the smallest even integer with $r' > d/2$, one has the representation

$$N(E) = \|f\|_2^{-2} \mathbb{E}\{\text{Trace}(f^* \Theta(E - H(V)) f)\} \tag{2.8}$$

with any non-zero $f \in L^2(\mathbb{R}^d)$, which, inside the trace, is to be understood as an operator of multiplication. Moreover, $\Theta(E - H(V^{(\omega)}))$ denotes the spectral projection operator of $H(V^{(\omega)})$ associated with the open interval $] -\infty, E[$. As a consequence, the set of growth points of N coincides with the \mathbb{P} -almost sure spectrum of $H(V)$.

Proof. Concerning assertion (i) we refer to Thm. 1 in [KM]. The existence and non-randomness of the integrated density of states is shown

in Thm. VI.1.1 in [CL] for the case $a=0$ by using functional-integral techniques for the Laplace transforms of the density-of-states measures. Employing the appropriate Feynman–Kac–Itô formula and so-called magnetic translations, these methods generalize in a straightforward manner to the present setting with a constant magnetic field [BHL1, U]. Note also that pointwise convergence of the Laplace transforms of a sequence of measures implies pointwise convergence of the associated distribution functions at all continuity points of the limit. Alternatively, (2.7) may be obtained from a purely functional-analytic argument, which is outlined in [M]. The representation (2.8) claimed in (iii) is contained in [PF] as Thm. 5.20 and Prob. II.4 in the case $a=0$; for the extension to $a \neq 0$ see [HLMW]. The proof of (2.8) uses the resolvent of $H(V)$. In contrast, the proof of part (ii) relies on semigroup techniques. This explains the different assumptions in (ii) and (iii). The assertion on the growth points of N follows from (2.8). ■

2.2. Gaussian Random Potentials and Main Result

A random field on \mathbb{R}^d is called Gaussian, if all its finite-dimensional marginal distributions are Gaussians. Such a random field is completely characterized—up to equality in distribution—by its mean function $\mathbb{R}^d \ni x \mapsto \mathbb{E}\{V(x)\}$ and its covariance kernel $\mathbb{R}^d \times \mathbb{R}^d \ni (x, y) \mapsto \mathbb{E}\{V(x)V(y)\}$. The reader is referred to [Ad, Li, Y] for detailed expositions about Gaussian random fields.

Definition 2.6. A *Gaussian random potential* on \mathbb{R}^d (with zero mean) is an \mathbb{R}^d -homogeneous Gaussian random field $V: \Omega \times \mathbb{R}^d \rightarrow \mathbb{R}$, $(\omega, x) \mapsto V^{(\omega)}(x)$, on a complete probability space $(\Omega, \mathcal{A}, \mathbb{P})$ such that $\mathbb{E}\{V\} = 0$ and the covariance function $\mathbb{R}^d \ni x \mapsto C(x) := \mathbb{E}\{V(x)V(0)\}$ is continuous at the origin where it obeys $0 < C(0) < \infty$.

Remark 2.7. Given a Gaussian random potential on \mathbb{R}^d there exists a length $\ell_C > 0$ such that $C(x) > 0$ for all $x \in A_{\ell_C}(0)$ due to our continuity requirement.

Lemma 2.8. A Gaussian random potential on \mathbb{R}^d is a random potential on \mathbb{R}^d in the sense of Definition 2.1.

Proof. A covariance function C which is continuous at the origin, where it satisfies $C(0) < \infty$, is bounded and uniformly continuous on \mathbb{R}^d by the Bochner–Khintchine theorem. Consequently, Thm. 3.2.2 in [F] implies the existence of a separable version of V which is jointly measurable with respect to the sigma-algebra \mathcal{A} and the Borel sigma-algebra on \mathbb{R}^d . From

now on it is tacitly assumed that only this version will be dealt with when we refer to a Gaussian random potential. It remains to verify (2.3). To this end choose an even natural number $p_1 > p(d) + d/2$. Then there exists $p_2 \in \mathbb{R}$ such that $p_1 > p_2 > p_1 d / [2(p_1 - p(d))]$. Jensen's inequality, the homogeneity of V and the explicit computation of the arising Gaussian integral now imply

$$\begin{aligned} \mathbb{E}\{\|V\|_{p_1; A_1(0)}^{p_2}\} &\leq (\mathbb{E}\{\|V\|_{p_1; A_1(0)}^{p_1}\})^{p_2/p_1} \\ &= (\mathbb{E}\{|V(0)|^{p_1}\})^{p_2/p_1} \\ &= (C(0))^{p_2/2} \prod_{k=1}^{p_1/2} (2k-1)^{p_2/p_1} < \infty \quad \blacksquare \end{aligned} \tag{2.9}$$

Remark 2.9. Given a Gaussian random potential V , then Lemma 2.8 allows to define the associated random Schrödinger operators as in Proposition 2.3. Proposition 2.5 is then applicable, too, under the additional assumptions stated there. Note also that the additional requirements in parts (ii) and (iii) of Proposition 2.5 are fulfilled because of $\mathbb{E}\{\exp[-tV(0)]\} = \exp\{t^2 C(0)/2\} < \infty$ for all $t \in \mathbb{R}$.

Before we formulate a spectral-localization theorem for Schrödinger operators with Gaussian random potentials, it is convenient to define a couple of properties which a Gaussian random potential on \mathbb{R}^d may have or not.

(P) Its covariance function C is non-negative.

(H) C is locally Hölder continuous at the origin with some Hölder exponent $0 < \beta \leq 1$, that is, $C(0) - C(x) \leq b |x|_\infty^\beta$ for all x in some neighbourhood of the origin and some constant $b > 0$.

(R) C admits the representation

$$C(x) = \int_{\mathbb{R}^d} d^d y \gamma(x+y) \gamma(y) \tag{2.10}$$

where γ is a non-negative function on \mathbb{R}^d which satisfies the inequality $\gamma(x) \leq \gamma_0 (1 + |x|)^{-\zeta}$ for all $x \in \mathbb{R}^d$ with some constants $\gamma_0 > 0$ and $\zeta > 13d/2 + 1$. Moreover, it is assumed to be uniformly Hölder continuous with some Hölder exponent $0 < \alpha \leq 1$, that is, $|\gamma(x+y) - \gamma(x)| \leq a |y|_\infty^\alpha$ for all $x \in \mathbb{R}^d$, all y in some neighbourhood of the origin and some constant $a > 0$.

(D) C decays (at least) algebraically at infinity, $|C(x)| \leq C_0 (1 + |x|)^{-z}$ for all $x \in \mathbb{R}^d$ with some constants $0 < C_0 < \infty$ and $z > 4d + 3/2$.

(E) V is ergodic.

(M) There are constants $K_0 \geq 2$ integer, $A > 0$, $1 < \nu < 1 + (8d)^{-1}$ and $\delta > 4(d-1)(\nu-1)/(2-\nu)$ such that the strong-mixing coefficient (2.4) of V satisfies the inequality

$$\alpha_V(l^\nu/4, (K_0 - 1)l^d) \leq A(1+l)^{-\delta} \quad (2.11)$$

for all lengths $l > 0$.

Remarks 2.10. (i) The Hölder continuity property (H) implies the \mathbb{P} -almost sure continuity, and hence local boundedness, of the realizations of V , see Section 5.1.

(ii) The existence of the representation (2.10) in itself with some $\gamma \in L^2(\mathbb{R}^d)$ is equivalent to the requirement that C is the Fourier transform of a non-negative integrable function on \mathbb{R}^d . This is in fact a rather weak requirement which is sometimes referred to as the Wiener–Khinchine criterion.

(iii) If C had a representation (2.10) with γ obeying $\int_{\mathbb{R}^d} d^d x \gamma(x) = 0$, then the Gaussian random potential could be constructed from a sequence of Poissonian random potentials in a suitably combined limit of infinite concentration of impurities and zero coupling of the single-impurity potential. Within this interpretation γ would appear as the scaled impurity potential of the Poissonian random potential.

(iv) Property (D) implies property (E), because according to Example 1.15(c) in [PF] the decay of C at infinity implies even mixing.

(v) Property (R) implies properties (P), (H) and (D). If, in addition, γ has compact support, then property (M) is implied, too. Indeed, for Gaussian random potentials V the local sigma-algebras $\mathcal{A}_V(A)$ and $\mathcal{A}_V(A')$ are independent, if $\text{dist}_\infty(A, A') > L$ with L such that the support of C obeys $\text{supp } C \subset A_{2L}(0)$.

(vi) Property (M) implies that the random potential V is strongly mixing. More precisely, $\lim_{L \rightarrow \infty} L^\mu \alpha_V(L, G) = 0$ for all $G > 0$ and all $\mu < \delta/\nu$. The strong-mixing property is considerably stronger [D] than the usually required ergodicity (E). We do not know however whether properties (M) and (D) are related to each other. In one dimension, strongly mixing random fields are completely non-deterministic (in other words: regular), see e.g., [Gri] or p. 21 in [D]. Whereas for one dimension there is a well-developed theory [IR] characterizing the covariance functions of strongly mixing Gaussian random potentials, this seems to be an open problem for higher dimensions. However, more is known in the discrete case, that is, for random fields on the d -dimensional simple cubic lattice \mathbb{Z}^d , see e.g., Section 2.1 in [D].

Examples 2.11. (i) The Gaussian random potential on \mathbb{R} characterized by the exponential covariance $C(x) = C(0) \exp\{-|x|/\xi\}$, $\xi > 0$, has the properties (P), (H), (D) and (M). While the first three are obvious, the last one follows from Thm. 6 in Chap. VI of [IR].

(ii) The Gaussian covariance function $C(x) = C(0) \exp\{-x^2/(2\lambda^2)\}$, $\lambda > 0$, has the property (R) for arbitrary dimension $d \geq 1$. Note that for $d=1$ this example gives rise to a so-called deterministic (in other words: singular) random field, whose realizations are \mathbb{P} -almost surely real-analytic functions [Bel]. Hence, property (M) does not hold for $d=1$, cf. Remark 2.10(vi). This is also meant as a warning that even a very fast decay of C at infinity need not imply the strong-mixing property.

Now we can state the *main result* of this paper.

Theorem 2.12. Let V be a Gaussian random potential on \mathbb{R}^d with covariance function $\mathbb{R}^d \ni x \mapsto \sigma^2 C(x)$, where $\sigma > 0$ and C has either property (R) or the four properties (P), (H), (D) and (M). Let $H(V)$ be the associated random Schrödinger operator defined on the Hilbert space $L^2(\mathbb{R}^d)$ as in Proposition 2.3. Then, given any $\sigma > 0$ there is a finite energy $E_0 < 0$ such that the spectrum of $H(V)$ in the half-line $] -\infty, E_0]$ is \mathbb{P} -almost surely only pure point. Moreover, given any finite energy $E_0 < 0$ there is a $\sigma_0 > 0$ such that the spectrum of $H(V)$ in $] -\infty, E_0]$ is \mathbb{P} -almost surely only pure point for all $\sigma \in]0, \sigma_0]$.

Remarks 2.13. (i) It is not required in Theorem 2.12 that the vector potential a generates a spatially constant magnetic-field tensor. But if it does, then the assumptions of Theorem 2.12 ensure that the components in the Lebesgue decomposition of the spectrum of $H(V)$ are \mathbb{P} -almost surely non-random sets, see Remark 2.9 and Proposition 2.5(i). Moreover, the spectrum of $H(V)$ is \mathbb{P} -almost surely equal to the whole real line, as can be seen by following the steps in the proof of Thm. 5.34(i) in [PF].

(ii) We believe that the assumption $C \geq 0$ is only a technical one. We need it for the proof of the Wegner estimate and in order to exclude the existence of the singular continuous spectrum.

(iii) The assumptions of the theorem require a compromise between local dependence and global independence of V , as can be inferred from Remarks 2.10(i), (iv), (v) and (vi). From a physical point of view, both requirements are plausible: The effective one-particle potential should be smooth due to screening. By the same token it is expected that impurities do not influence each other over large distances.

(iv) The assumptions of the theorem allow for deterministic random potentials, cf. Example 2.11(ii). Since this is not the case for many other

localization results for multi-dimensional space, the method of proof which we present here may also be interesting from a conceptual point of view.

(v) We are not able to prove exponential decay of the eigenfunctions $\psi_n^{(\omega)} \in L^2(\mathbb{R}^d)$ associated with eigenenergies $E_n^{(\omega)} \in]-\infty, E_0]$. If such a result is true, it can certainly not be proven by a straightforward modification of our approach.

(vi) It would be interesting to prove spectral localization also for strong disorder or at positive energies, e.g., in between Landau levels. Unfortunately, we do not know of the appropriate initial estimates for the multi-scale analysis.

(vii) The assertions of the theorem remain true with E_0 below the bottom of the spectrum of $H(0)$, if $H(0)$ is generalized to include a (sufficiently well-behaved) periodic potential. For energies in the spectral gaps of $H(0)$ however, it is again the lack of appropriate initial estimates which prevents us from proving localization.

Our proof of Theorem 2.12 relies on a multi-scale analysis which requires a so-called Wegner estimate as an important ingredient. Such an estimate bounds the mean number of eigenvalues in a given energy interval of the finite-volume random Schrödinger operator by the length of the interval and the volume of the cube.

2.3. Wegner Estimate for Gaussian Random Potentials

In Thm. 1 and Rem. 3(ii) of [FHLM2] a Wegner estimate is obtained for Schrödinger operators with certain Gaussian random potentials for the case without magnetic field. It was however already pointed out there in the “Note added in proof” that the result continues to hold if a suitable magnetic vector potential is included. Indeed, the two main technical steps in the proof remain valid in the presence of a (continuously differentiable) vector potential a . The first step concerns the lowering of the eigenvalues of $H_\lambda(V)$ in inequality (27) of [FHLM2] by Dirichlet–Neumann bracketing and the subsequent introduction of “Neumann interfaces.” The second step is the application of the abstract one-parameter spectral-averaging estimate Cor. 4.2 of [CH1]. Moreover, by applying the diamagnetic inequality for Neumann partition functions, the Wegner constant (2.13) below, derived for the case $a=0$ in [FHLM2], is seen to be a Wegner constant also for $a \neq 0$. For the technical details we refer to [HLMW]. We state the Wegner estimate as

Proposition 2.14. Let V be a Gaussian random potential on \mathbb{R}^d with property (P), let the associated finite-volume random Schrödinger

operator be defined as in Proposition 2.3 and define the length $\ell_C > 0$ as in Remark 2.7. Then, for every energy $E \in \mathbb{R}$ there is a constant $0 < W(E) < \infty$, depending on ℓ_C , such that for all $E_1, E_2 \leq E$ and all bounded open cubes $A \subset \mathbb{R}^d$ with $|A| \geq \ell_C^d$ the averaged finite-volume integrated density of states (2.6) obeys

$$\mathbb{E}\{|N_A(E_1) - N_A(E_2)|\} \leq |A| |E_1 - E_2| W(E) \tag{2.12}$$

Remarks 2.15. (i) The Wegner estimate (2.12) holds under weaker assumptions on V which are stated in [FHLM2] or [HLMW]. Since we need stronger assumptions on V in this paper in order to prove localization, we contented ourselves to formulate Proposition 2.14 within the latter setting.

(ii) The Wegner constant $W(E)$ may be taken [FHLM2] as

$$W(E) = \frac{\exp\{tE + t^2 C_E/2\}}{\sqrt{2\pi C(0)} b_E} (2\ell_E^{-1} + (2\pi t)^{-1/2})^d \tag{2.13}$$

where $t > 0$ is arbitrary and may be considered as a variational parameter. In (2.13) we are using the constants $\ell_E := \inf\{|E|^{-1/2}, \ell_C\}$, $b_E := \inf_{|x|_\infty < \ell_E/2} \{C(x)/C(0)\} > 0$ and $C_E := C(0)(2 - b_E^2)$. The simple (but not optimal) choice $t = (2C_E)^{-1} (-E + \sqrt{E^2 + 2C_E/\pi})$ gives the leading asymptotic low- and high-energy behaviour

$$\lim_{E \rightarrow -\infty} \frac{\ln W(E)}{E^2} = -\frac{1}{2C(0)}, \quad \lim_{E \rightarrow \infty} \frac{W(E)}{E^{d/2}} = \frac{3^d e^{1/(2\pi)}}{\sqrt{2\pi C(0)}} \tag{2.14}$$

(iii) The Lipschitz continuity (2.12) of the averaged finite-volume integrated density of states implies by the Chebyshev–Markov inequality that the probability of finding the spectrum of $H_A(V)$ near a given energy \tilde{E} is controlled by the inequality

$$\mathbb{P}\{\omega : \text{dist}(\text{spec}(H_A(V^{(\omega)})), \tilde{E}) < \varepsilon\} \leq 2 |A| \varepsilon W(E) \tag{2.15}$$

It is valid for all bounded open cubes $A \subset \mathbb{R}^d$ with $|A| \geq \ell_C^d$ and for all energies $\tilde{E} \in \mathbb{R}$ and $\varepsilon > 0$ such that $\tilde{E} + \varepsilon \leq E$.

(iv) Apart from [FHLM2], we know of [CH1, Ki2, KSS2, CHM, Z, St], where a Wegner estimate is proven for correlated random potentials in multi-dimensional continuous space.

Recalling Remark 2.9 and Proposition 2.5(ii) on the existence of the integrated density of states, we conclude from the reasoning in [FHLM2] that Proposition 2.14 has the following

Corollary 2.16. Assume that the vector potential a generates a constant magnetic-field tensor and that the Gaussian random potential V has the properties (P) and (E). Then, the integrated density of states N is absolutely continuous on any bounded interval and its derivative, the density of states, is locally bounded in the sense that

$$0 \leq \frac{dN(E)}{dE} \leq W(E) \quad (2.16)$$

for Lebesgue-almost all $E \in \mathbb{R}$.

Remarks 2.17. (i) Of course, the assumption of a constant magnetic-field tensor is not really necessary. Corollary 2.16 holds for all vector potentials a which give rise to an ergodic random Schrödinger operator $H(V)$.

(ii) One must not expect that (2.16) with $W(E)$ given by (2.13) is a sharp bound on the density of states dN/dE , since neither special properties of the covariance function C have entered nor has the vector potential a . Whereas we conjecture that (2.14) reflects the true asymptotic behaviour at low energies of the density of states dN/dE , this should not be true for the high-energy asymptotics. For example, we conjecture that the density of states behaves like $E^{d/2-1}$ for $E \rightarrow \infty$ in the case $a=0$.

3. MULTI-SCALE ANALYSIS

The heart of the localization proof given in this paper is a multi-scale analysis in the spirit of the fundamental work [FS]. It provides probabilistic bounds on the resolvents of finite-volume random Schrödinger operators. The technical realization of the multi-scale analysis used here is patterned after [DK2] and [CH1] in order to cope with a correlated random potential and a continuous space, respectively; for the latter aspect see also [FK]. In addition, to overcome difficulties arising from long-range spatial correlations, we allow for different random potentials on different length scales. The idea behind this is to replace a given long-range correlated random potential V on the length scale L_k by the element V_k of a sequence $\{V_k\}_{k \in \mathbb{N}_0}$ of random potentials such that (i) $\{V_k\}$ converges to V in a suitable sense and (ii) each V_k has short-range correlations, but their spatial extent grows with increasing k .

We do not restrict ourselves to Gaussian random potentials in this section, but only require the setting of Proposition 2.3. The main technical result of this section is stated as Theorem 3.14 in Subsection 3.2. In Subsection 3.3 we perform the macroscopic limit to infinite volume.

3.1. Boxes and Geometric Resolvent Equation

A box $B \subseteq \mathbb{R}^d \times \mathbb{R}_0^+$ is a pair (A, b) consisting of an open cube $A \subseteq \mathbb{R}^d$ and the width $b \geq 0$ of the frame $\{x \in A : \text{dist}_\infty(x, \partial A) \leq b\}$ of B . The box $B = (A, b)$ is said to be contained in the box $B' = (A', b')$, in symbols, $B < B'$, if $A \subset A'$ and $\text{dist}_\infty(A, \partial A') > b'$.

By definition, a (mollified) indicator function χ_B of a box $B := (A_\ell(y), b) \subset \mathbb{R}^d \times \mathbb{R}_0^+$ has the properties

- (i) $0 \leq \chi_B \leq 1$,
- (ii) $\chi_B(x) = \begin{cases} 1 & \text{if } |x - y|_\infty < \ell/2 - 2b/3, \\ 0 & \text{if } |x - y|_\infty \geq \ell/2 - b/3. \end{cases}$

Moreover, if $b > 0$ we infer from Uryson’s lemma in the version of Thm. 1 of Sect. 3.4 in [R] that

(iii) $\chi_B \in \mathcal{C}_0^\infty(\mathbb{R}^d)$,

(iv) there exist positive real constants $\varkappa_1, \varkappa_2, \varkappa_4 > 0$, which are independent of B , such that

$$\|\nabla \chi_B\|_\infty \leq \varkappa_1/b \tag{3.1}$$

$$\|\nabla^2 \chi_B\|_\infty \leq \varkappa_2/b^2 \tag{3.2}$$

$$\|\nabla^2 |\chi_B|^2\|_\infty \leq \varkappa_4/b^4 \tag{3.3}$$

We set $\chi_{(\mathbb{R}^d, 0)} := 1$. For $b > 0$ we say that χ_B^∂ is an indicator function of the frame of the box B , if it has the properties

- (i) $\chi_B^\partial \in \mathcal{C}_0^\infty(\mathbb{R}^d)$,
- (ii) $0 \leq \chi_B^\partial \leq 1$,
- (iii) $\chi_B^\partial(x) = \begin{cases} 1 & \text{if } \ell/2 - 2b/3 \leq |x - y|_\infty \leq \ell/2 - b/3, \\ 0 & \text{if } |x - y|_\infty \leq \ell/2 - b \text{ or } |x - y|_\infty \geq \ell/2. \end{cases}$

For an illustration of χ_B and χ_B^∂ see Fig. 1. Finally, we introduce a frame operator Γ_B as the first-order differential operator given by

$$\Gamma_B := \frac{1}{2}(\nabla^2 \chi_B) - (i\nabla \chi_B) \cdot (i\nabla + a) \tag{3.4}$$

with domain $\mathcal{D}(-\Delta_A) \subset L^2(A)$. Here $\nabla^n \chi_B$, $n = 1, 2$, acts as a multiplication operator, and a is the vector potential, see Proposition 2.3.

Remark 3.1. Obviously, the following operator identities hold

$$\chi_B^\partial \nabla^n \chi_B = \nabla^n \chi_B, \quad n = 1, 2 \tag{3.5}$$

$$\Gamma_B = \chi_B^\partial \Gamma_B = \Gamma_B \chi_B^\partial \quad \text{on } \mathcal{D}(-\Delta_A) \quad \text{for } B = (A, b) \tag{3.6}$$

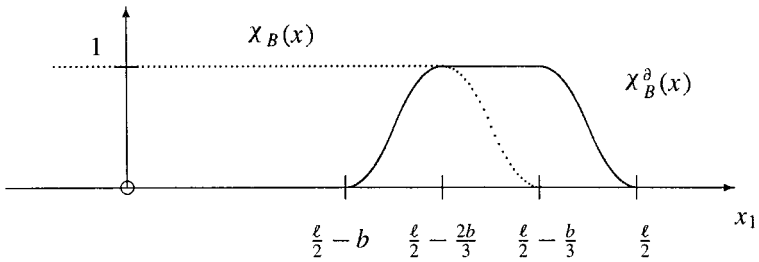

Fig. 1. Sketch of indicator functions of the box $B = (A_I(0), b)$ (dotted line) and of the frame of B (solid line) as a function of x_1 for $x_j = 0, j = 2, \dots, d$.

For the rest of this section let $v \in L_{loc}^{p(d)}(\mathbb{R}^d)$ be a non-random real scalar potential, let $a: \mathbb{R}^d \rightarrow \mathbb{R}^d$ be a continuously differentiable vector potential with $\nabla \cdot a = 0$ and let $H_A(v)$ be defined as in (2.5). The constant $p(d)$ was defined in Definition 2.1.

Lemma 3.2. For $b, b' > 0$ let $B = (A, b)$ and $B' = (A', b')$ be boxes such that $B < B'$. Then for all $z \in \mathbb{C} \setminus \mathbb{R}$ the geometric resolvent equation

$$(H_{A'}(v) - z)^{-1} \chi_B = \chi_B (H_A(v) - z)^{-1} + (H_{A'}(v) - z)^{-1} \Gamma_B (H_A(v) - z)^{-1} \tag{3.7}$$

holds on $L^2(A')$.

Remark 3.3. (i) For (3.7) to make sense as an operator identity on $L^2(A')$, operators which are *a priori* only defined on $L^2(A)$ are supposed to be trivially extended to $L^2(A')$ by setting them to zero on $L^2(A' \setminus A)$. This convention will be used throughout the paper without further notice.

(ii) The proof of Lemma 3.2 follows from writing $\Gamma_B = \chi_B (H_A(v) - z)^{-1} - (H_A(v) - z) \chi_B$.

In what follows it will be useful to introduce the abbreviations

$$R_{B', B}(v, z) := \Gamma_{B'}(H_{A'}(v) - z)^{-1} \chi_B \tag{3.8}$$

and

$$W_{B', B}(v, z) := \Gamma_{B'}(H_{A'}(v) - z)^{-1} \chi_B^\partial \tag{3.9}$$

We will omit the arguments v and z when this does not cause confusion.

Remarks 3.4. (i) The definitions of χ , χ° , R and W imply for all $B < B' < B''$ the relations

$$R_{B'', B'} \chi_B = R_{B'', B} \tag{3.10}$$

$$R_{B'', B'} \chi_B^\circ = W_{B'', B} \tag{3.11}$$

(ii) Using the definitions of R and W , the geometric resolvent equation of Lemma 3.2 with boxes $B < B'$ implies

$$R_{B', B}(v, z) = W_{B', B}(v, z) R_{B, (A, 0)}(v, z) \tag{3.12}$$

We finish this subsection with a lemma which estimates $R_{B', B}$ in terms of a “localized” resolvent by bounding $G_{B'}$. This result will only be needed in Section 5.

Lemma 3.5. Consider two boxes $B = (A, 0)$ and $B' = (A', b')$ with $b' > 0$, $A \subseteq A'$ and A' bounded. Then one has

$$\begin{aligned} & \sup_{\eta > 0} \|R_{B', B}(v, E + i\eta)\| \\ & \leq \Phi_{B'}(E - v) \sup_{\eta > 0} \|\chi_{B'}^\circ(H_{A'}(v) - E - i\eta)^{-1} \chi_B\| \\ & \quad + \Theta(b' - \text{dist}_\infty(\partial A', A)) \frac{2^{1/2} \kappa_1}{b'} \sup_{\eta > 0} \|(H_{A'}(v) - E - i\eta)^{-1}\|^{1/2} \end{aligned} \tag{3.13}$$

for Lebesgue-almost all $E \in \mathbb{R}$. Here we used Heaviside’s unit-step function $\Theta(t) := \begin{cases} 1 & \text{if } t > 0 \\ 0 & \text{if } t \leq 0 \end{cases}$ and introduced the functional

$$\Phi_{B'}(f) := \frac{1}{b'^2} \left(\frac{\kappa_2}{2} + \sqrt{\frac{\kappa_4}{2} + 2(b' \kappa_1)^2 \|\max\{0, f\}\|_{\infty; A'}} \right) \tag{3.14}$$

which is defined for real-valued functions $f \in L^\infty(A')$. If $f \notin L^\infty(A')$, we set $\Phi_{B'}(f) := \infty$.

The proof of Lemma 3.5 relies on a partial-integration result for the scalar product (2.2) on $L^2(A)$. It is an extension to non-zero vector potentials a of Eq. (2.7) in [CFKS] and replaces the wrong equality at the bottom of p. 175 in [CH1].

Lemma 3.6. Let A be a bounded open subset of \mathbb{R}^d , let $\psi \in \mathcal{D}(-A_A)$, let $\phi \in \mathcal{C}^2(\mathbb{R}^d)$ real and let $a: \mathbb{R}^d \rightarrow \mathbb{R}^d$ be continuously differentiable with $\nabla \cdot a = 0$, then

$$\langle \phi, |(i\nabla + a) \psi|^2 \rangle = \frac{1}{2} \langle \nabla^2 \phi, |\psi|^2 \rangle + \text{Re} \{ \langle \psi \phi, (i\nabla + a)^2 \psi \rangle \} \tag{3.15}$$

Proof. Using $|\nabla\psi|^2 = (1/2) \nabla^2 |\psi|^2 - \operatorname{Re}\{\psi^* \nabla^2 \psi\}$, we rewrite the left-hand side of (3.15) as

$$\langle \phi, ((1/2) \nabla^2 |\psi|^2 + \operatorname{Re}\{\psi^* (i\nabla)^2 \psi\} + a^2 |\psi|^2 + 2 \operatorname{Re}\{(i\nabla\psi) \cdot a\psi^*\}) \rangle \quad (3.16)$$

The first term on the right-hand side of (3.15) follows from a double partial integration and the rest from the reality of ϕ and the gauge condition $\nabla \cdot a = 0$. ■

Proof of Lemma 3.5. We infer from the definition (3.4) of $\Gamma_{B'}$ and (3.2) that

$$\|\Gamma_{B'} \psi\| \leq \frac{\varkappa_2}{2b'^2} \|\chi_{B'}^\partial \psi\| + \|(\nabla \chi_{B'}) \cdot (i\nabla + a) \psi\| \quad (3.17)$$

When applied to $\psi = (H_{A'}(v) - E - i\eta)^{-1} \chi_B g$, where $g \in L^2(A')$ with $\|g\| = 1$, Eq. (3.17) yields the claim of the lemma, provided the second term on the right-hand side of (3.17) is shown to be appropriately bounded in terms of $\|\chi_{B'}^\partial \psi\|$. To do so we estimate

$$\begin{aligned} \|(\nabla \chi_{B'}) \cdot (i\nabla + a) \psi\|^2 &\leq \| |\nabla \chi_{B'}| |(i\nabla + a) \psi| \|^2 \\ &= \langle |\nabla \chi_{B'}|^2, |(i\nabla + a) \psi|^2 \rangle \end{aligned} \quad (3.18)$$

Since $\mathcal{D}(H_{A'}(v)) = \mathcal{D}(-A_{A'})$, we can apply Lemma 3.6 to the scalar product. Together with

$$(i\nabla + a)^2 \psi = 2\chi_B g + 2(E + i\eta - v) \psi \quad (3.19)$$

this gives

$$\begin{aligned} &\|(\nabla \chi_{B'}) \cdot (i\nabla + a) \psi\|^2 \\ &\leq \frac{1}{2} \langle \nabla^2 |\nabla \chi_{B'}|^2, |\psi|^2 \rangle + 2 \operatorname{Re}\{ \langle \psi | \nabla \chi_{B'}|^2, (\chi_B g + (E + i\eta - v) \psi) \rangle \} \\ &\leq \left(\frac{\varkappa_4}{2b'^4} + \frac{2\varkappa_1^2}{b'^2} \|\max\{0, E - v\}\|_{\infty; A'} \right) \|\chi_{B'}^\partial \psi\|^2 \\ &\quad + \Theta(b' - \operatorname{dist}_\infty(\partial A', A)) \frac{2\varkappa_1^2}{b'^2} \|\psi\| \end{aligned} \quad (3.20)$$

To derive the first line of the last inequality, we refer to (3.5), (3.3) and (3.1). The second line follows from the Schwarz inequality, (3.1) and

$\|g\| = 1$. Thus, the claim is obtained by inserting (3.20) into (3.17) and by observing $\sqrt{\alpha^2 + \beta^2} \leq \alpha + \beta$ for $\alpha, \beta \geq 0$. ■

3.2. Estimating Resolvents on Multiple Length Scales by Induction

Throughout this subsection we will consider a fixed real number $\nu > 1$ and a fixed natural number $N > 4$. Given a length $L > 2^{2\nu/(\nu-1)}N$ and a point $x \in \mathbb{R}^d$, we define a family of $N+1$ nested boxes

$$B_n^L(x) := \begin{cases} (A_{L/(4N)}(x), 0) & \text{if } n = 0 \\ \left(A_{nL/N}(x), \frac{(L/N)^{1/\nu}}{4N} \right) & \text{if } 1 \leq n \leq N-1 \\ (A_L(x), L/(4N)) & \text{if } n = N \end{cases} \quad (3.21)$$

see Fig. 2.

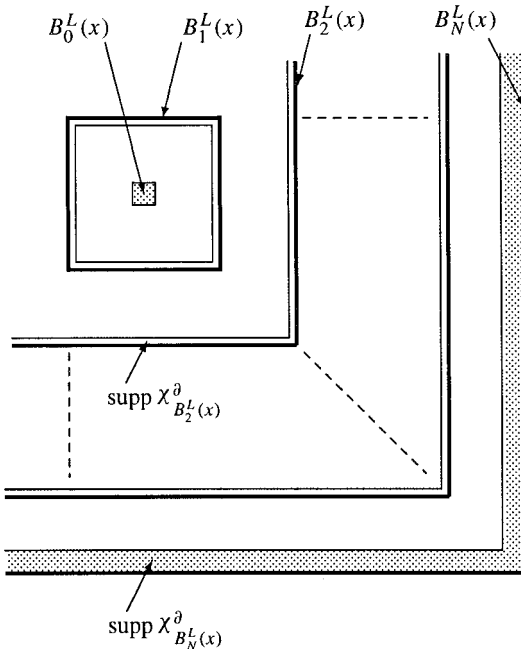

Fig. 2. Sketch for $d=2$ of the boxes defined in (3.21).

Definition 3.7. Let $E \in \mathbb{R}$ and $r > 0$. The potential v is said to be (r, E, L, x) -regular, if

$$\sup_{\eta > 0} \|R_{B_N^L(x), B_0^L(x)}(v, E + i\eta)\| \leq L^{-r} \quad (3.22)$$

Now we come to the deterministic part of the recursion clause of the multi-scale analysis. The aim is to infer the (r, E, L, x) -regularity of a suitable potential v' from the (r, E, ℓ, y) -regularity of v on the smaller length $\ell := (L/N)^{1/\nu}$ for suitable $y \in \mathbb{R}^d$. To this end, choose a natural number $2 \leq S \leq N-1$, a sequence $\{n_s\}_{s=1, \dots, S}$ of natural numbers with $1 \leq n_1 < \dots < n_S \leq N-1$, and apply (3.10) and (3.12) to get $R_{B_N^L(x), B_0^L(x)} = W_{B_N^L(x), B_{n_1}^L(x)} R_{B_{n_1}^L(x), B_0^L(x)}$, where the pair of arguments $(v, E + i\eta)$ has been suppressed in the three operators. Using (3.11) and (3.12) we derive the relation $W_{B_N^L(x), B_{n_s}^L(x)} = W_{B_N^L(x), B_{n_{s+1}}^L(x)} W_{B_{n_{s+1}}^L(x), B_{n_s}^L(x)}$ for $s = 1, \dots, S-1$ which, upon iteration with respect to s , leads to

$$R_{B_N^L(x), B_0^L(x)} = W_{B_N^L(x), B_{n_S}^L(x)} \cdots \cdots W_{B_{n_2}^L(x), B_{n_1}^L(x)} R_{B_{n_1}^L(x), B_0^L(x)} \quad (3.23)$$

for the given pair $(v, E + i\eta)$. For each $1 \leq n \leq N-1$ we “tile”—as indicated in Fig. 3—the frame of $B_n^L(x)$ with a total number

$$\tau_n^L \leq 2d(4nL(N/L)^{1/\nu} + 1)^{d-1} \quad (3.24)$$

of boxes $B_0^\ell(y)$, whose centres y define the set $T_n^L(x)$, that is, $\text{supp } \chi_{B_n^L(x)}^\partial \subseteq \overline{\bigcup_{y \in T_n^L(x)} A_{\ell/(4N)}(y)}$. Hence, $\chi_{B_n^L(x)}^\partial \leq \sum_{y \in T_n^L(x)} \chi_{B_n^\ell(y)} \chi_{B_0^\ell(y)}$ and one deduces for $n < n' \leq N$ with the help of Remarks 3.4

$$\begin{aligned} \|W_{B_{n'}^L(x), B_n^L(x)}\| &\leq \sum_{y \in T_n^L(x)} \|R_{B_{n'}^L(x), B_n^\ell(y)} \chi_{B_0^\ell(y)}\| \\ &\leq \sum_{y \in T_n^L(x)} \|W_{B_{n'}^L(x), B_{n'}^L(y)}\| \|R_{B_{n'}^L(y), B_0^\ell(y)}\| \end{aligned} \quad (3.25)$$

This motivates the following two definitions.

Definition 3.8. Let $w \geq 0$. The potential v is said to be (w, E, L, x) -non-resonant, if

$$\max_{1 \leq n \leq N-1} \sup_{\eta > 0} \|R_{B_n^L(x), B_0^L(x)}(v, E + i\eta)\| \leq L^w \quad (3.26a)$$

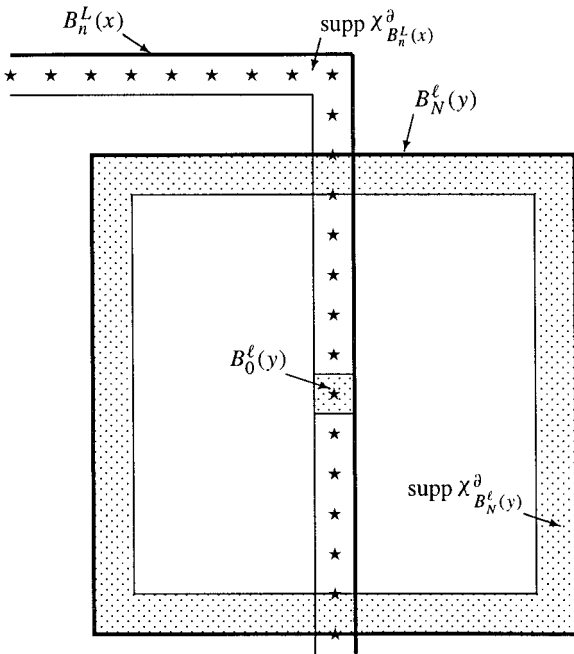

Fig. 3. Sketch of the geometric situation on the frame of $B_n^L(x)$ for $1 \leq n \leq N-1$ and $d=2$. The points marked by \star make up the set $T_n^L(x)$ and are the centres of the “tiling” of the frame of $B_n^L(x)$. For one $y \in T_n^L(x)$ the boxes $B_0^\ell(y)$ and $B_N^\ell(y)$ are sketched.

and

$$\max_{1 \leq n < n' \leq N} \max_{y \in T_n^L(x)} \sup_{\eta > 0} \|W_{B_n^L(x), B_{n'}^\ell(y)}(v, E + i\eta)\| \leq L^w \quad (3.26b)$$

where $\ell := (L/N)^{1/\nu}$.

Definition 3.9. The potential v is said to be (r, E, L, S, x) -frame-regular, if there exist S natural numbers $1 \leq n_1 < \dots < n_S \leq N-1$ such that v is (r, E, ℓ, y) -regular for all $y \in T_{n_s}^L(x)$ and all $1 \leq s \leq S$, where $\ell := (L/N)^{1/\nu}$.

Up to this point we were only concerned with a single potential v . In order to allow for another potential v' , which is supposed to have the same properties as v , we use the second resolvent equation

$$R_{B_N^L(x), B_0^L(x)}(v', z) = R_{B_N^L(x), B_0^L(x)}(v, z) + D_x^L(v', v, z) \quad (3.27)$$

where $\text{Im } z \neq 0$ and D_x^L is defined in

Definition 3.10. The potential v is said to be an (r, E, L, x) -approximation of the potential v' if

$$\sup_{\eta > 0} \|D_x^L(v', v, E + i\eta)\| \leq \frac{L^{-r}}{2} \quad (3.28)$$

where

$$D_x^L(v', v, z) := R_{B_N^L(x), (A_L(x), 0)}(v, z)(v - v')(H_{A_L(x)}(v') - z)^{-1} \chi_{B_0^L(x)} \quad (3.29)$$

Combining (3.27) with (3.23)–(3.25) we summarize the deterministic part of the recursion clause of the multi-scale analysis in

Lemma 3.11 (Deterministic Part). Let $(S - \nu)r > \nu w(S + 1) + (d - 1)(\nu - 1)S$ and assume L to be sufficiently large. If v is (r, E, L, S, x) -frame-regular, (w, E, L, x) -non-resonant and an (r, E, L, x) -approximation of v' , then v' is (r, E, L, x) -regular.

Next we come to the probabilistic part of the recursion clause of the multi-scale analysis. For this purpose let \tilde{V} be a random potential on \mathbb{R}^d in the sense of Definition 2.1. In order to allow for spatially correlated random potentials it is necessary to control the probability for the joint occurrence of spatially separated events. More precisely, we have to ensure that this probability decreases sufficiently fast with increasing separation.

Definition 3.12. Let $K \geq 2$ integer and $\varrho, \vartheta > 0$. A random potential \tilde{V} is said to be $(K, L, \varrho, \vartheta)$ -independent, if

$$\mathbb{P} \left(\bigcap_{k=1}^K A_k \right) \leq (L/N)^{-K\varrho\vartheta/\nu} \quad (3.30)$$

for all local events $A_k \in \mathcal{A}_{\tilde{V}}(A_k)$, $k = 1, \dots, K$, which satisfy $\mathbb{P}(A_k) \leq (L/N)^{-\varrho/\nu}$, and all Borel sets $A_k \subset \mathbb{R}^d$ subject to $|A_k| \leq (L/N)^{d/\nu}$ and

$$\text{dist}_\infty(A_k, A_{k'}) \geq L/(4N), \quad \text{for } k \neq k' \quad (3.31)$$

The sub-sigma-algebra $\mathcal{A}_{\tilde{V}}(A_k)$ was defined in Definition 2.2.

Lemma 3.13 (Probabilistic Part). Let $2 \leq S \leq N - 2$ and let $((N - S)\vartheta - \nu)\varrho > (\nu - 1)(d - 1)(N - S)$. Assume L to be sufficiently large such that, among others, $\ell := (L/N)^{1/\nu} \geq 4^{1/(\nu-1)}$. If \tilde{V} is $(N - S, L, \varrho, \vartheta)$ -independent and

$$\mathbb{P}\{\omega : \tilde{V}^{(\omega)} \text{ is } (r, E, \ell, x)\text{-regular}\} \geq 1 - \ell^{-\varrho} \quad (3.32)$$

for all $x \in \mathbb{R}^d$, then

$$\mathbb{P}\{\omega : \tilde{V}^{(\omega)} \text{ is } (r, E, L, S, x)\text{-frame-regular}\} \geq 1 - L^{-e}/2 \tag{3.33}$$

for all $x \in \mathbb{R}^d$.

Proof. We will estimate from above the probability for the event that \tilde{V} is not (r, E, L, S, x) -frame-regular. Introducing the event

$$A(y) := \{\omega : \tilde{V}^{(\omega)} \text{ is not } (r, E, \ell, y)\text{-regular}\} \in \mathcal{A}_{\tilde{V}}(A_I(y)) \tag{3.34}$$

one gets from elementary set-theoretic algebra

$$\begin{aligned} & \mathbb{P}\{\omega : \tilde{V}^{(\omega)} \text{ is not } (r, E, L, S, x)\text{-frame-regular}\} \\ & \leq \sum_{1 \leq n_1 < \dots < n_{N-S} \leq N-1} \mathbb{P}\left(\bigcap_{k=1}^{N-S} \left(\bigcup_{y_k \in T_{n_k}^L} A(y_k)\right)\right) \\ & \leq \sum_{1 \leq n_1 < \dots < n_{N-S} \leq N-1} \sum_{y_1 \in T_{n_1}^L} \dots \sum_{y_{N-S} \in T_{n_{N-S}}^L} \mathbb{P}\left(\bigcap_{k=1}^{N-S} A(y_k)\right) \end{aligned} \tag{3.35}$$

By assumption one has $\mathbb{P}(A(y_k)) \leq \ell^{-e}$, $|A_\ell(y_k)| = \ell^d$ and $\text{dist}_\infty(A_\ell(y_k), A_\ell(y_{k'})) \geq L/(2N) - \ell \geq L/(4N)$ for $k \neq k'$. Thus, the $(N-S, L, \varrho, \vartheta)$ -independence of \tilde{V} implies

$$\mathbb{P}\left(\bigcap_{k=1}^{N-S} A(y_k)\right) \leq (L/N)^{-(N-S) \varrho \vartheta/\nu} \tag{3.36}$$

With the help of this inequality and (3.24) one gets an (n_1, \dots, n_{N-S}) -independent upper bound for the sums over y_1, \dots, y_{N-S} in the last line of (3.35). The remaining multiple sum gives a binomial coefficient. Hence

$$\begin{aligned} & \mathbb{P}\{\omega : \tilde{V}^{(\omega)} \text{ is not } (r, E, L, S, x)\text{-frame-regular}\} \\ & \leq \binom{N-1}{N-S} (2d)^{N-S} \left[4(N-1) L \left(\frac{N}{L}\right)^{1/\nu} + 1 \right]^{(d-1)(N-S)} \left(\frac{N}{L}\right)^{(N-S) \varrho \vartheta/\nu} \\ & \leq L^{-e}/2 \end{aligned} \tag{3.37}$$

if L is sufficiently large. ■

The main technical result of this paper, Theorem 3.14 below, is a multi-scale analysis for truly continuum correlated random potentials. More precisely, it involves a sequence $\{V_k\}_{k \in \mathbb{N}_0}$ of random potentials which converges suitably to a random potential V .

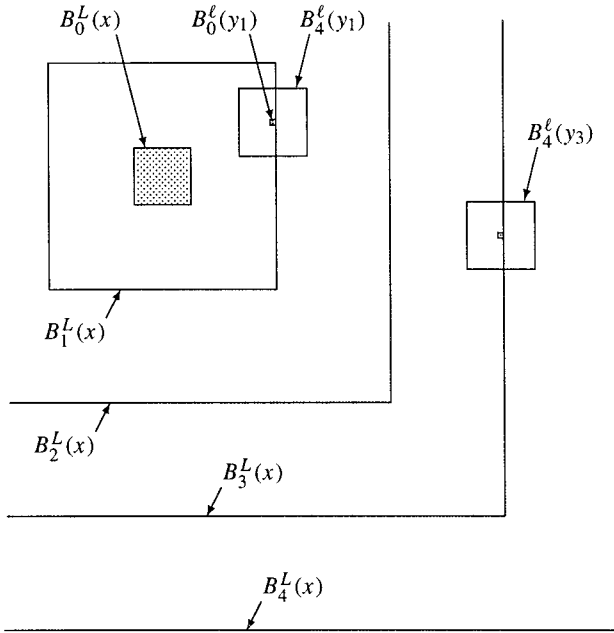

Fig. 4. Sketch of the geometric situation considered in Theorem 3.14 for $d=2$, $N=4$ and $S=2$. The points y_1 and y_3 are elements of the sets $T_1^L(x)$, respectively $T_3^L(x)$.

Theorem 3.14. Let V and V_k , $k \in \mathbb{N}_0$, be random potentials on \mathbb{R}^d in the sense of Definition 2.1. Assume that the underlying probability space is the same for all these random potentials and that the assumptions of Proposition 2.3 hold. Let $N \geq 4$ and $2 \leq S \leq N - 2$ be natural numbers, let $\vartheta, \nu, \varrho, r, w, L_0$ be positive constants such that $\nu > 1$, $L_0^{\nu-1} \geq 4$ and let $\{I_k\}_{k \in \mathbb{N}_0}$ be a sequence of Lebesgue measurable sets such that $I_k \subseteq I_0 \subseteq \mathbb{R}$ for all $k \in \mathbb{N}_0$. Define a sequence of lengths $\{L_k\}_{k \in \mathbb{N}_0}$ through $L_k := N^{(\nu^k - 1)/(\nu - 1)} L_0^{\nu^k}$, that is,

$$L_{k+1} = NL_k^\nu \tag{3.38}$$

and assume that the following five conditions hold for all $k \in \mathbb{N}_0$:

- (i) $(S - \nu)r > (\nu - 1)(d - 1)S + \nu w(S + 1)$.
- (ii) $((N - S)\vartheta - \nu)\varrho > (\nu - 1)(d - 1)(N - S)$.
- (iii) V_k is $(N - S, L_k, \varrho, \vartheta)$ -independent.

(iv) For all $E \in I_0$, for all $x \in \mathbb{R}^d$ and for both $U^{(\omega)} = V_{k+1}^{(\omega)}$ and $U^{(\omega)} = V^{(\omega)}$ one has

$$\mathbb{P}\{\omega : V_k^{(\omega)} \text{ is } (w, E, L_k, x)\text{-non-resonant and an } (r, E, L_k, x)\text{-approximation of } U^{(\omega)}\} \geq 1 - L_k^{-e}/2$$

(v) For all $E \in I_k$ and for all $x \in \mathbb{R}^d$ one has

$$\mathbb{P}\{\omega : V_k^{(\omega)} \text{ is } (r, E, L_k, x)\text{-regular}\} \geq 1 - L_k^{-e}$$

Then there is a $k_0 \in \mathbb{N}$ such that for all $k > k_0$, for all $E \in I_{k_0}$ and for all $x \in \mathbb{R}^d$ one has

$$\mathbb{P}\{\omega : V^{(\omega)} \text{ is } (r, E, L_k, x)\text{-regular}\} \geq 1 - L_k^{-e} \tag{3.39}$$

Remark 3.15. The subsequent proof shows that (3.39) also holds with $V^{(\omega)}$ replaced by $V_k^{(\omega)}$. In either case one should notice that for all $k > k_0$ Eq. (3.39) holds for all energies E in the fixed set I_{k_0} , whereas the so-called Initial–Estimate Assumption (v) is only required to hold for energies in sets I_k which may become gradually smaller with increasing k .

Proof of Theorem 3.14. Theorem 3.14 is proven by induction on k . Pick $k_0 \in \mathbb{N}$ such that $L := L_{k_0+1}$ is large enough as required for the applicability of Lemmas 3.11 and 3.13. Let $U^{(\omega)}$ stand for either $V^{(\omega)}$ or $V_{k_0+1}^{(\omega)}$. Due to Assumption (i) we can apply Lemma 3.11 with $v = V_{k_0}^{(\omega)}$ and $v' = U^{(\omega)}$. For given $E \in \mathbb{R}$ and given $x \in \mathbb{R}^d$ this yields

$$\begin{aligned} &\mathbb{P}\{\omega : U^{(\omega)} \text{ is } (r, E, L_{k_0+1}, x)\text{-regular}\} \\ &\geq -1 + \mathbb{P}\{\omega : V_{k_0}^{(\omega)} \text{ is } (r, E, L_{k_0+1}, S, x)\text{-frame-regular}\} \\ &\quad + \mathbb{P}\{\omega : V_{k_0}^{(\omega)} \text{ is } (w, E, L_{k_0+1}, x)\text{-non-resonant and an } (r, E, L_{k_0+1}, x)\text{-approximation of } U^{(\omega)}\} \end{aligned} \tag{3.40}$$

Thanks to Assumptions (ii), (iii) and (v) we thus conclude from Lemma 3.13 and (iv) that for all $E \in I_{k_0}$ and all $x \in \mathbb{R}^d$

$$\mathbb{P}\{\omega : U^{(\omega)} \text{ is } (r, E, L_{k_0+1}, x)\text{-regular}\} \geq 1 - L_{k_0+1}^{-e} \tag{3.41}$$

Choosing $U^{(\omega)} = V^{(\omega)}$ in (3.41), we obtain (3.39) for $k = k_0 + 1$. Choosing $U^{(\omega)} = V_{k_0+1}^{(\omega)}$ in (3.41), we get for all $E \in I_{k_0}$ the substitute for (v) on the length scale L_{k_0+1} which allows one to repeat the above procedure inductively. ■

3.3. Macroscopic Limit and Absence of the Absolutely Continuous Spectrum

Starting from the multi-scale estimates (3.39), one can try to calculate a variety of quantities, describing dynamical localization properties, e.g., conductivities in the sense of Kubo or diffusion exponents [FS, MH, GB, AG, BFM, DS]. Here we shall concentrate on spectral properties. The assertion of the following theorem for the infinite-volume random Schrödinger operator $H(V)$ allows one to exclude the absolutely continuous spectrum for the energies under consideration and also serves as a starting point for the exclusion of the singular continuous spectrum with the help of the methods of Theorem 4.1.

Theorem 3.16. Assume the situation of Proposition 2.3. Fix $N \in \mathbb{N}$, a Lebesgue measurable set $I \subseteq \mathbb{R}$, $L_0 > 1$, $\nu > 1$ and set $L_k := N^{(\nu^k - 1)/(\nu - 1)} L_0^{\nu^k}$ for $k \in \mathbb{N}$. Assume further that

$$\mathbb{P}\{\omega : V^{(\omega)} \text{ is } (r, E, L_k, 0)\text{-regular}\} \geq 1 - L_k^{-\varrho} \quad (3.42)$$

and

$$\mathbb{P}\{\omega : \text{dist}(\text{spec}(H_{A_{L_k}}(V^{(\omega)})), E) \leq L_k^{-m}\} \leq L_k^{-\mu} \tilde{W} \quad (3.43)$$

holds for all $k \in \mathbb{N}$ and all $E \in I$ with suitable constants $r, \varrho, m, \mu, \tilde{W} > 0$, obeying $r > 4m\nu$. Then, for all functions $\varphi \in L^2(\mathbb{R}^d)$ $|\varphi(x)| \leq \varphi_0(1 + |x|)^{-\beta}$, for Lebesgue-almost all $x \in \mathbb{R}^d$ with some constants $\varphi_0 < \infty$ and $\beta > 2m\nu^2$, the inequality

$$\sup_{\eta > 0} \|(H(V^{(\omega)}) - E - i\eta)^{-1} \varphi\| < \infty \quad (3.44)$$

holds for *Lebesgue* \otimes \mathbb{P} -almost all pairs $(E, \omega) \in I \times \Omega$.

Proof. We show that the theorem is a special case of Cor. 2.2 in [CH1]. The inequalities $r > 4m\nu$ and $\beta > 2m\nu^2$ imply the existence of $r' < r$ with $4m\nu < r' < 2\beta/\nu$. Then estimate (3.42) still holds when r is replaced by r' . Now we choose the quantities l_k, ε_k, f of [CH1] according to $l_k = L_k$, $\varepsilon_k = L_{k-1}^{-r'/2}$, $f(t) = N^{-m} t^{2m\nu/r'}$. The sequences l_k , resp. ε_k , are monotone increasing, resp. decreasing with $\lim_{k \rightarrow \infty} \varepsilon_k = 0$. Since $r' > 4m\nu$ one has $1/f \in L^2_{\text{loc}}(\mathbb{R})$. The sequences $L_k^{-\mu}$, $L_k^{-\varrho}$ and $\varepsilon_{k+1}^{-1} l_{k-1}^{-\beta}$ are summable because $\mu, \varrho > 0$ and $\beta > r'\nu/2$. Hence, all the assumptions of Cor. 2.2 in [CH1] are satisfied such that (3.44) follows \mathbb{P} -almost surely for all $E \in I$. Since the resolvent of $H(V^{(\omega)})$ is jointly measurable in E and ω , the subset of pairs $(E, \omega) \in I \times \Omega$ for which (3.44) holds is measurable with respect to the product-sigma-algebra and has full *Lebesgue* \otimes \mathbb{P} -measure by Fubini's theorem. ■

Corollary 3.17. Under the assumptions of Theorem 3.16 the random Schrödinger operator $H(V)$ has \mathbb{P} -almost surely no absolutely continuous spectrum in I .

Proof. Let $\{u_n\}_{n \in \mathbb{N}}$ be a complete orthonormal sequence of vectors in $L^2(\mathbb{R}^d)$ and suppose that $|u_n(x)| \leq u_{n,0}(1 + |x|)^{-\beta}$ for all $x \in \mathbb{R}^d$ with some constants $u_{n,0} < \infty$ and β as in Theorem 3.16. It suffices to show that the event

$$\{\omega : \langle u_n, F_{ac}(V^{(\omega)}, I) u_n \rangle = 0 \text{ for all } n \in \mathbb{N}\} \tag{3.45}$$

occurs with probability one. Here, $\langle \cdot, \cdot \rangle$ is the scalar product (2.2) on $L^2(\mathbb{R}^d)$, and $F_{ac}(V^{(\omega)}, \cdot)$ denotes the absolutely continuous component arising in the Lebesgue decomposition of the projection-valued spectral measure of $H(V^{(\omega)})$. But this follows from

$$\begin{aligned} & \int_{\Omega} d\mathbb{P}(\omega) \langle u_n, F_{ac}(V^{(\omega)}, I) u_n \rangle \\ &= \frac{1}{\pi} \int_{\Omega} d\mathbb{P}(\omega) \left(\int_I dE \lim_{\eta \searrow 0} \text{Im} \langle u_n, (H(V^{(\omega)}) - E - i\eta)^{-1} u_n \rangle \right) \\ &= \frac{1}{\pi} \int_{I \times \Omega} dE \otimes d\mathbb{P}(\omega) \lim_{\eta \searrow 0} (\eta \| (H(V^{(\omega)}) - E - i\eta)^{-1} u_n \|^2) \\ &= 0 \end{aligned} \tag{3.46}$$

where we have used the Theorem of Fatou and de la Vallée Poussin, see e.g., Thm. A.10 in [PF], Fubini’s Theorem and (3.44). ■

4. PURE-POINT SPECTRUM

From the last section we know that the results of the multi-scale analysis for energies in $I \subset \mathbb{R}$ suffice to exclude the existence of the absolutely continuous spectrum of the infinite-volume random Schrödinger operator $H(V)$ in I with probability one. In order to exclude the singular continuous spectrum as well, and hence to show that the spectrum of $H(V)$ is \mathbb{P} -almost surely only pure point in I , additional assumptions and efforts are needed. This is accomplished by Theorem 4.1 below, which adapts and elaborates on some results of Simon and Wolff [SW], Howland [Ho] and Combes and Hislop [CH1] in order to be applicable to truly continuum random potentials admitting a rather general one-parameter decomposition.

Theorem 4.1. Assume the situation of Proposition 2.3. Furthermore, let $n > d/4$ be a natural number such that

- (i) $\mathbb{E}\{|V(0)|^{2n}\} =: c_n < \infty$,
- (ii) V admits a one-parameter decomposition

$$V^{(\omega)} = U^{(\omega)} + \lambda^{(\omega)}u$$

for \mathbb{P} -almost all ω , where $U: \Omega \times \mathbb{R}^d \rightarrow \mathbb{R}$ is a random field (which, in general, is not homogeneous), $u \in L^n(\mathbb{R}^d) \cap L^\infty(\mathbb{R}^d)$ is a strictly positive function and $\lambda: \Omega \rightarrow \mathbb{R}$ is a random variable whose conditional probability measure relative to the sub-sigma-algebra $\mathcal{A}_U \subseteq \mathcal{A}$ generated by $\{U(x)\}_{x \in \mathbb{R}^d}$ has a density $\varrho: \Omega \times \mathbb{R} \rightarrow \mathbb{R}^+$ with respect to Lebesgue measure, which is measurable with respect to the product sigma-algebra $\mathcal{A}_U \otimes \mathcal{L}$. Here, \mathcal{L} is the sigma-algebra of Lebesgue measurable sets in \mathbb{R} ,

- (iii) there exists $I \in \mathcal{L}$ such that for \mathbb{P} -almost all $\omega \in \Omega$ one can find $I_0 \in \mathcal{L}$ with $I_0(\omega) \subseteq I$ and $|I \setminus I_0(\omega)| = 0$ such that

$$\sup_{\eta > 0} \|(H(V^{(\omega)}) - E - i\eta)^{-1} u^{1/2}\| < \infty \quad \text{for all } E \in I_0(\omega)$$

Then, the spectrum of $H(V)$ is \mathbb{P} -almost surely only pure point in I .

The proof of Theorem 4.1 relies on a deterministic result about the instability of the singular continuous spectrum under perturbations. We quote a special case of Thm. 3.2 in [CH1] as

Proposition 4.2. Let h_0 be a self-adjoint operator with domain $\mathcal{D}(h_0) \subseteq L^2(\mathbb{R}^d)$. For a bounded, non-negative, self-adjoint operator h_1 and $\xi \in \mathbb{R}$ define $h(\xi) := h_0 + \xi h_1$ on $\mathcal{D}(h_0)$ and assume that

- (i) there is $J \in \mathcal{L}$ such that $h_1^{1/2}(h_0 - E - i\eta)^{-1} h_1^{1/2}$ is compact for all $\eta > 0$ and all $E \in J$,
- (ii) there is $J_0 \in \mathcal{L}$ with $J_0 \subseteq J$ and $|J \setminus J_0| = 0$ such that

$$\sup_{\eta > 0} \|(h_0 - E - i\eta)^{-1} h_1^{1/2}\| < \infty \quad \text{for all } E \in J_0$$

- (iii) the subspace $\{h_1^{1/2}\psi : \psi \in L^2(\mathbb{R}^d)\}$ is dense in $L^2(\mathbb{R}^d)$.

Then, for Lebesgue-almost all $\xi \in \mathbb{R}$ the spectrum of $h(\xi)$ is only pure point in J with finitely degenerate eigenvalues.

Proof of Theorem 4.1. Let us define the function $X: \Omega \times \mathbb{R} \rightarrow \{0, 1\}$ by setting $X^{(\omega)}(\xi) = 0$, if a one-parameter decomposition of V exists in the

sense of Assumption (ii), the operator $H(U^{(\omega)} + \xi u)$ is self-adjoint and its spectrum is only pure point in I . Otherwise we set $X^{(\omega)}(\xi) = 1$. The joint measurability of the random potential V implies that the random potential $((\omega, \xi), x) \mapsto U^{(\omega)}(x) + \xi u(x)$ is jointly measurable with respect to the product sigma-algebra $(\mathcal{A}_U \otimes \mathcal{L}) \otimes \mathcal{B}^d$, where \mathcal{B}^d is the sigma-algebra of the Borel sets in \mathbb{R}^d . Accordingly, [KM] implies the joint measurability of X with respect to the completion $(\mathcal{A}_U \otimes \mathcal{L})^\sim$ of $\mathcal{A}_U \otimes \mathcal{L}$ induced by the product measure $\mathbb{P} \otimes \text{Lebesgue}$. We also define the Ω -subsets

$$\begin{aligned} \Omega_1 &:= \{\omega \in \Omega : X^{(\omega)}(\lambda^{(\omega)}) = 0\} \\ \Omega_0 &:= \left\{ \omega \in \Omega : \int_{\mathbb{R}} d\xi X^{(\omega)}(\lambda^{(\omega)} + \xi) = 0 \right\} \end{aligned} \quad (4.1)$$

Apart from the \mathbb{P} -null set allowed for in Assumption 4.1(ii), Ω_1 is the set of ω 's for which $H(V^{(\omega)})$ enjoys the property of being self-adjoint with only pure-point spectrum in I . Hence, we know from Proposition 2.3(iii) that $\Omega_1 \in \mathcal{A}$. Analogously, up to the same \mathbb{P} -null set, Ω_0 is the set of ω 's such that for Lebesgue-almost all $\xi \in \mathbb{R}$ the operator $H(V^{(\omega)} + \xi u)$ is self-adjoint with only pure-point spectrum in I . The \mathcal{A} -measurability of Ω_0 follows from the completeness of \mathcal{A} , the joint measurability of X and Fubini's theorem.

We split the rest of the proof into two parts. In part (a) we show that $\mathbb{P}(\Omega_0) = 1$ implies $\mathbb{P}(\Omega_1) = 1$ and in part (b) that the assumptions of the theorem imply $\mathbb{P}(\Omega_0) = 1$.

(a) Suppose $\mathbb{P}(\Omega_0) = 1$, then we have

$$0 = \mathbb{E} \left\{ \int_{\mathbb{R}} d\xi X(\lambda + \xi) \right\} = \mathbb{E} \left\{ \int_{\mathbb{R}} d\xi X(\xi) \right\} \quad (4.2)$$

and Fubini's theorem gives $X^{(\omega)}(\xi) = 0$ for almost all pairs $(\omega, \xi) \in \Omega \times \mathbb{R}$ with respect to the completed measure $(\mathbb{P} \otimes \text{Lebesgue})^\sim$. It follows the existence of $Y: \Omega \times \mathbb{R} \rightarrow \{0, 1\}$ such that $X \leq Y$, Y is $\mathcal{A}_U \otimes \mathcal{L}$ -measurable and $X^{(\omega)}(\xi) = Y^{(\omega)}(\xi)$ for $\mathbb{P} \otimes \text{Lebesgue}$ almost all $(\omega, \xi) \in \Omega \times \mathbb{R}$. Indeed, the level set $\{(\omega, \xi) \in \Omega \times \mathbb{R} : X^{(\omega)}(\xi) = 0\} \in (\mathcal{A}_U \otimes \mathcal{L})^\sim$ differs at most by a $(\mathbb{P} \otimes \text{Lebesgue})^\sim$ -null set from a product measurable set $\Xi \in \mathcal{A}_U \otimes \mathcal{L}$. Now define $Y^{(\omega)}(\xi) = 0$ for all $(\omega, \xi) \in \Xi$ and $Y^{(\omega)}(\xi) = 1$ elsewhere. Thus, we conclude from Fubini's theorem that

$$0 = \mathbb{E} \left\{ \int_{\mathbb{R}} d\xi \varrho(\xi) Y(\xi) \right\} = \mathbb{E} \{ \mathbb{E} \{ Y(\lambda) \mid \mathcal{A}_U \} \} = \mathbb{E} \{ Y(\lambda) \} \quad (4.3)$$

The second equality in (4.3) follows from a slight generalization of the “Disintegration Theorem 5.4” in [Ka] and uses the fact that the $\mathcal{A}_U \otimes \mathcal{L}$ -measurable Lebesgue density ϱ provides a regular version of the conditional probability measure of λ for given \mathcal{A}_U . Hence, $Y^{(\omega)}(\lambda^{(\omega)}) = 0$ for \mathbb{P} -almost all $\omega \in \Omega$. Since $0 \leq X \leq Y$ this implies $\mathbb{P}(\Omega_1) = 1$.

(b) The aim is to derive $\mathbb{P}(\Omega_0) = 1$ from the conclusion of Proposition 4.2. To this end we have to ensure that the assumptions of Proposition 4.2 are satisfied for \mathbb{P} -almost all $\omega \in \Omega$ when setting $h_1 = u$, $J = I$ and $h_0 = H(V^{(\omega)})$.

Recall that by assumption, u is a strictly positive, bounded function and that by Proposition 2.3(ii) $H(V)$ is \mathbb{P} -almost surely essentially self-adjoint on $\mathcal{C}_0^\infty(\mathbb{R}^d)$. Obviously, Assumption 4.1(iii) is identical to Assumption 4.2(ii), if we also set $J_0 = I_0(\omega)$.

As to Assumption 4.2(iii), suppose that φ is in the orthogonal complement \mathcal{H}^\perp of the norm-closed subspace $\mathcal{H} := \{u^{1/2}\psi : \psi \in L^2(\mathbb{R}^d)\}^{\text{cl}}$ of $L^2(\mathbb{R}^d)$. Since $u^{1/2}\varphi \in \mathcal{H}$ it follows that

$$0 = \langle \varphi, u^{1/2}\varphi \rangle = \int_{\mathbb{R}^d} d^d x |\varphi(x)|^2 (u(x))^{1/2} \quad (4.4)$$

From $u(x) > 0$ for Lebesgue-almost all $x \in \mathbb{R}^d$ we conclude $\varphi(x) = 0$ for Lebesgue-almost all $x \in \mathbb{R}^d$ so that $\mathcal{H}^\perp = \{0\}$ and $\mathcal{H} = L^2(\mathbb{R}^d)$, proving 4.2(iii).

It remains to verify Assumption 4.2(i), that is, the \mathbb{P} -almost sure compactness of $u^{1/2}(H(V) - E - i\eta)^{-1} u^{1/2}$ for all $\eta > 0$ and all $E \in I$. Because of the boundedness of u it is sufficient to show that the operator

$$u^{1/2}(H(V^{(\omega)}) - z)^{-1} \quad (4.5)$$

is compact for z equal to some fixed $z_0 \in \mathbb{C} \setminus \mathbb{R}$ for \mathbb{P} -almost all $\omega \in \Omega$. Note that compactness of (4.5) for some z_0 implies compactness of (4.5) for all $z \in \mathbb{C} \setminus \mathbb{R}$. Hence the set of ω 's for which (4.5) is compact does not depend on $z \in \mathbb{C} \setminus \mathbb{R}$. By the second resolvent equation

$$\begin{aligned} & u^{1/2}(H(V^{(\omega)}) - z_0)^{-1} \\ &= u^{1/2}(H(0) - z_0)^{-1} - u^{1/2}(H(0) - z_0)^{-1} V^{(\omega)}(H(V^{(\omega)}) - z_0)^{-1} \end{aligned} \quad (4.6)$$

it suffices in turn to prove compactness of $u^{1/2}(H(0) - z_0)^{-1}$ and of $u^{1/2}(H(0) - z_0)^{-1} V^{(\omega)}$ for \mathbb{P} -almost all $\omega \in \Omega$. We note that the validity of the resolvent equation (4.6) itself is ensured by this compactness and the fact that (4.6) obviously holds on the subspace $\{\psi \in L^2(\mathbb{R}^d) : \psi = (H(V^{(\omega)}) - z_0)\phi, \phi \in \mathcal{C}_0^\infty(\mathbb{R}^d)\}$ which, according to the Cor. on p. 257 in [RS1] is dense in $L^2(\mathbb{R}^d)$, because $H(V^{(\omega)})$ is essentially self-adjoint on $\mathcal{C}_0^\infty(\mathbb{R}^d)$.

To show this compactness put $z_0 = \tilde{E} + i\eta$ with $\tilde{E} < 0$, $\eta \neq 0$, and observe the diamagnetic inequality (see e.g., [CFKS]) for the integral kernels of the resolvents of $H(0)$ and $-A/2$

$$|(H(0) - z_0)^{-1}(x, y)| \leq (-A/2 - \tilde{E})^{-1}(x, y) =: G_1(x - y) \tag{4.7}$$

which are jointly continuous on $\{(x, y) \in \mathbb{R}^d \times \mathbb{R}^d : x \neq y\}$. Let $n > d/4$ be the natural number defined in Assumption 4.1(i). Then, we have for both $j = 0$ and $j = 1$ the inequality

$$\begin{aligned} & \mathbb{E}\{\text{Trace}\{[(u^{1/2}(H(0) - z_0)^{-1} V^j)(u^{1/2}(H(0) - z_0)^{-1} V^j)^\dagger]^n\}\} \\ & \leq \mathbb{E}\left\{\int_{\mathbb{R}^d} d^d x_1 \int_{\mathbb{R}^d} d^d y_1 \cdots \int_{\mathbb{R}^d} d^d x_n \int_{\mathbb{R}^d} d^d y_n \left(\prod_{v=1}^n u(x_v) |V(y_v)|^{2j}\right) \right. \\ & \quad \left. \times G_1(x_1 - y_1) G_1(y_1 - x_2) \cdots G_1(x_n - y_n) G_1(y_n - x_1)\right\} \\ & \leq c_n^j \int_{\mathbb{R}^d} d^d r_2 \cdots \int_{\mathbb{R}^d} d^d r_n G_2(-r_2) G_2(r_2 - r_3) \cdots G_2(r_{n-1} - r_n) G_2(r_n) \\ & \quad \times \int_{\mathbb{R}^d} d^d r_1 u(r_1) u(r_1 + r_2) \cdots u(r_1 + r_n) \\ & \leq c_n^j \|u\|_n^n G_{2n}(0) \end{aligned} \tag{4.8}$$

To obtain the second inequality in (4.8) we have used the iterated Hölder inequality in order to employ Assumption 4.1(i), the convolution property

$$G_{k+1}(x - y) = \int_{\mathbb{R}^d} d^d w G_k(x - w) G_1(w - y) \tag{4.9}$$

for the k -times iterated integral kernel $G_k(x - y) := (-A/2 - \tilde{E})^{-k}(x, y)$ and the change-of-variables $r_1 := x_1$, $r_l := x_l - x_1$ for $l = 2, \dots, n$. The last inequality in (4.8) follows from the iterated Hölder inequality and (4.9). Since $u \in L^n(\mathbb{R}^d)$ and $G_{2n}(0) = (2\pi)^{-d} \int_{\mathbb{R}^d} d^d p ((p^2/2) - \tilde{E})^{-2n}$, the upper bound (4.8) is finite because of $n > d/4$. Hence, the operator $u^{1/2}(H(0) - z_0)^{-1} V^j$ is \mathbb{P} -almost surely compact for both $j = 0$ and $j = 1$ by Prop. 6 on p. 42 in [RS2]. ■

5. PROOF OF THE MAIN THEOREM 2.12

In this section we prove Theorem 2.12 by showing that the assumptions of the more general theorems of Sections 3 and 4 are fulfilled for the Gaussian random potentials under consideration. The main result of this section is the following Theorem 5.1, which establishes multi-scale

estimates in the low-energy and weak-disorder regime. These estimates for the finite-volume resolvents will then be transported to the infinite-volume resolvent in Corollary 5.2 by means of Theorem 3.16. Given Corollary 5.2, the proof of Theorem 2.12 is finally completed by an application of Theorem 4.1.

Theorem 5.1. Let V be a Gaussian random potential on \mathbb{R}^d with covariance function $x \mapsto \sigma^2 C(x)$, where $\sigma > 0$ and C has either property (R) or the three properties (P), (H) and (M). Let $H(V)$ be the associated random Schrödinger operator as in Proposition 2.3. Then there are a natural number $N \geq 4$ and positive reals ν, ϱ, r obeying

$$1 < \nu < 1 + \frac{1}{8d} \quad (5.1)$$

and

$$4\nu d < r \quad (5.2)$$

such that the following two statements hold.

(i) For every $\sigma > 0$ there is $1 < L_0 < \infty$ and $-\infty < E_0 < 0$ such that

$$\mathbb{P}\{\omega : V^{(\omega)} \text{ is } (r, E, L_k, x)\text{-regular}\} \geq 1 - L_k^{-\varrho} \quad (5.3)$$

for all $x \in \mathbb{R}^d$ and all $E \in]-\infty, E_0]$, where $L_k := N^{(\nu k - 1)/(\nu - 1)} L_0^{\nu k}$, $k \in \mathbb{N}$.

(ii) For every $E_0 < 0$ there is $1 < L_0 < \infty$ and $\sigma_0 > 0$ such that for all $\sigma \in]0, \sigma_0]$ the inequality (5.3) holds for all $x \in \mathbb{R}^d$, all $E \in]-\infty, E_0]$ and all $k \in \mathbb{N}$.

For the time being let us assume that Theorem 5.1 is valid and proceed with the proof of Theorem 2.12.

Corollary 5.2. Assume the situation of Theorem 5.1. Then, for all functions $\varphi \in L^2(\mathbb{R}^d)$ with $|\varphi(x)| \leq \varphi_0(1 + |x|)^{-\beta}$ for some constants $\varphi_0 < \infty$ and $\beta > 2d + 3/4$ the inequality

$$\sup_{\eta > 0} \|(H(V^{(\omega)}) - E - i\eta)^{-1} \varphi\| < \infty \quad (5.4)$$

holds for Lebesgue $\otimes \mathbb{P}$ -almost all pairs $(E, \omega) \in]-\infty, E_0] \times \Omega$.

Proof. We check that the assumptions of Theorem 3.16 are fulfilled for $I :=]-\infty, E_0]$. Obviously, (5.3) provides (3.42). Since property (R) of

a Gaussian random potential implies property (P), the requirement (3.43) follows from the Wegner estimate in the weakened form (2.15), viz.

$$\mathbb{P}\{\omega : \text{dist}(\text{spec}(H_{A_{L_k}}(V^{(\omega)})), E) \leq L_k^{-m}\} \leq 2L_k^{d-m} W(E_0 + L_0^{-m}) \tag{5.5}$$

for all $k \in \mathbb{N}$ and all $E \in]-\infty, E_0]$. Thanks to (5.2) there exists a real constant m such that $d < m < \min\{r/(4v), d + (4v)^{-2}\}$. Hence, $\mu := m - d > 0$, $r > 4mv$ and, since $2mv^2 < 2d + 3/4$ according to (5.1), we obtain the lower bound $\beta > 2d + 3/4$ for the decay exponent β . ■

Proof of Theorem 2.12. We check the assumptions of Theorem 4.1 with $I :=]-\infty, E_0]$. Assumption 4.1(i) is obviously fulfilled for Gaussian random potentials for any $n \in \mathbb{N}$.

Concerning Assumption 4.1(ii) we introduce a one-parameter decomposition of V by defining the function

$$u(x) := \mathcal{N}^{-1/2} \int_{\mathbb{R}^d} d^d y e^{-y^2/2} C(x - y) \tag{5.6}$$

for $x \in \mathbb{R}^d$, $\mathcal{N} := \int_{\mathbb{R}^d} d^d x e^{-x^2/2} \int_{\mathbb{R}^d} d^d y e^{-y^2/2} C(x - y)$ being a normalization constant, the centred Gaussian random variable

$$\lambda^{(\omega)} := \mathcal{N}^{-1/2} \int_{\mathbb{R}^d} d^d y e^{-y^2/2} V^{(\omega)}(y) \tag{5.7}$$

with variance $\mathbb{E}(\lambda^2) = 1$ and the non-homogeneous Gaussian random field

$$U^{(\omega)}(x) := V^{(\omega)}(x) - \lambda^{(\omega)}u(x) \tag{5.8}$$

Due to the Gaussian nature of both λ and U , and due to $\mathbb{E}\{\lambda U(x)\} = 0$ for all $x \in \mathbb{R}^d$ we conclude that the random variable λ is stochastically independent of $\{U(x)\}_{x \in \mathbb{R}^d}$. Hence, the conditional probability density $\xi \mapsto \varrho^{(\omega)}(\xi) = (2\pi)^{-1/2} \exp\{-\xi^2/2\}$ of λ , given $\{U(x)\}_{x \in \mathbb{R}^d}$, is independent of ω and clearly has the desired measurability properties. Note that $u \in L^\infty(\mathbb{R}^d)$ is a strictly positive function because of Remark 2.10(v), property (P) and $C(0) > 0$. Moreover, it follows from the same remark and property (D) that

$$|u(x)| \leq u_0(1 + |x|)^{-z} \tag{5.9}$$

for all $x \in \mathbb{R}^d$, where $0 < u_0 < \infty$ and $z > 4d + 3/2$. Hence, $u \in L^n(\mathbb{R}^d)$ for any natural number $n > d/4$.

Finally (5.9) ensures that $u^{1/2}$ is an admissible choice for φ in Corollary 5.2, and Assumption 4.1(iii) is seen to hold by Corollary 5.2 and Fubini's theorem. ■

It remains to prove Theorem 5.1 by checking that the assumptions of Theorem 3.14 hold. This will be done in Subsection 5.4 below. The first three subsections are devoted to necessary preparations concerning the control of large fluctuations, the initial estimates and the control of long-range correlations, respectively.

5.1. Controlling Large Fluctuations

Typical realizations of Gaussian random potentials are unbounded. It is however possible to bound the probability that the absolute value of the realizations in a given cube exceeds a given value. This Lévy type of “maximal inequality” is the content of

Lemma 5.3. Consider a Gaussian random potential V on \mathbb{R}^d with property (H). Then, its realizations $x \mapsto V^{(\omega)}(x)$ are \mathbb{P} -almost surely continuous functions on \mathbb{R}^d and there exists a length $1 < \ell_H < \infty$ such that

$$\mathbb{P}\{\omega : \sup_{x \in A_\ell(0)} |V^{(\omega)}(x)| \geq E\} \leq 2^{2(d+1)} \exp\left\{-\frac{E^2}{200C(0) \ln \ell}\right\} \quad (5.10)$$

holds for all $\ell \geq \ell_H$ and all $E \geq 0$. The length ℓ_H depends only on the value of the Hölder exponent and the size of the neighbourhood referred to in property (H).

Proof. We deduce the lemma from Thm. 4.1.1 in [F]. When adapted to a homogeneous random field and a cube $A_\ell(0)$ with edges of length $\ell > 0$, this theorem implies that, if

$$\mathcal{J}(\ell) := \int_1^\infty dp \sup_{|x|_\infty \leq \ell 2^{-p^2}} \sqrt{C(0) - C(x)} < \infty \quad (5.11)$$

then the realizations of V are \mathbb{P} -almost surely continuous functions on $A_\ell(0)$, and the inequality

$$\mathbb{P}\{\omega : \sup_{x \in A_\ell(0)} |V^{(\omega)}(x)| \geq E\} \leq \frac{5}{2} 2^{2d} \int_{\xi_\ell(v)}^\infty dq e^{-q^2/2} \quad (5.12)$$

holds for all $E \geq 0$ obeying

$$\xi_\ell(E) := E[\sqrt{C(0)} + (2 + 2^{3/2}) \mathcal{J}(\ell)]^{-1} \geq \sqrt{1 + 4d \ln 2} \quad (5.13)$$

First, we verify that condition (5.11) is fulfilled for all $\ell > 1$ as a consequence of property (H). To this end we introduce $\theta > 0$ to characterize the

size of the neighbourhood referred to in property (H) by $|x|_\infty \leq \theta$. Without restriction we may assume that $\theta \leq \min\{1, (2C(0)/b)^{1/\beta}\}$. Hence, property (H) implies

$$\sup_{|x|_\infty \leq \ell 2^{-p^2}} (C(0) - C(x)) \leq b(\ell 2^{-p^2})^\beta \tag{5.14}$$

for all $p \geq p_0 := \sqrt{(\ln(\ell/\theta))/\ln 2}$. By extending the lower limit of the integration in (5.11) to zero, splitting the integral into two parts at p_0 and using $|C(x)| \leq C(0)$ in the first, respectively (5.14) in the second part, one arrives at the upper bound

$$\mathcal{J}(\ell) \leq \sqrt{2C(0) \frac{\ln(\ell/\theta)}{\ln 2}} + \sqrt{\frac{2b\ell^\beta}{\beta \ln 2}} \int_{\sqrt{(\beta/2) \ln(\ell/\theta)}}^\infty dp e^{-p^2} \tag{5.15}$$

Hence, $\mathcal{J}(\ell)$ is finite and Thm. 4.1.1 in [F] is applicable. In order to reduce the right-hand side of (5.12) to the more explicit (but less sharp) bound claimed in (5.10), we exploit

$$\int_s^\infty dp e^{-p^2} \leq \frac{\sqrt{\pi}}{2} e^{-s^2} \tag{5.16}$$

for $s \geq 0$, which follows from Formula 7.1.13 in [AbS]. Using this and $\theta^\beta \leq 2C(0)/b$, we continue to estimate (5.15) from above by

$$\mathcal{J}(\ell) \leq \left\{ \sqrt{\frac{2}{\ln 2} \left(1 - \frac{\ln \theta}{\ln \ell}\right)} + \sqrt{\frac{\pi}{\beta(\ln 2)(\ln \ell)}} \right\} \sqrt{C(0) \ln \ell} \tag{5.17}$$

The term in curly brackets in (5.17) approaches $\sqrt{2/\ln 2}$ as $\ell \rightarrow \infty$. Thus one can find a length $1 < \ell_H < \infty$, depending on θ and β , such that

$$\sqrt{C(0)} + (2 + 2^{3/2}) \mathcal{J}(\ell) \leq 10 \sqrt{C(0) \ln \ell} \tag{5.18}$$

holds for all $\ell \geq \ell_H$. Upon inserting this inequality and (5.16) into (5.12), we deduce (5.10) for all E obeying the condition (5.13). For those E not obeying (5.13), the inequality (5.10) is trivially true, because then its right-hand side is bigger than one by (5.18). ■

Remark 5.4. The bound (5.10) is very rough as can be inferred from the exact asymptotic behaviour

$$\lim_{v \rightarrow \infty} \frac{1}{v^2} \ln \mathbb{P}\{\omega : \sup_{x \in \mathcal{A}_r(0)} |V^{(\omega)}(x)| \geq v\} = -\frac{1}{2C(0)} \tag{5.19}$$

It is valid under the assumptions of Lemma 5.3 and the additional requirement that $C(x) \neq C(0)$ for all $x \in A_\rho(0) \setminus \{0\}$, see e.g., Thm. 8 in Section 14 of [Li] or [Ber]. For more stringent, but less explicit bounds than (5.10) the reader may consult [F, Li].

5.2. Initial Estimates

For the Gaussian model considered here, we are able to show spectral localization for low energies or weak disorder.

Lemma 5.5 (Low Energies). Let $\varrho, r_0 > 0$, $0 < r < r_0$ and $N \in \mathbb{N}$ be given and assume that the Gaussian random potential V with covariance function $x \mapsto \sigma^2 C(x)$ has property (H). Then, for every given $\sigma > 0$ there is a length $0 < L_H < \infty$ such that for every $L \geq L_H$ there is $-\infty < \varepsilon(L) < 0$ with

$$\mathbb{P}\{\omega : V^{(\omega)} \text{ is } (r, E, L, x)\text{-regular}\} \geq 1 - L^{-e} \quad (5.20)$$

for all $E \in]-\infty, \varepsilon(L)]$ and all $x \in \mathbb{R}^d$. The length L_H depends on N, r_0 and on the Hölder exponent and the size of the neighbourhood referred to in property (H).

Proof. Let

$$E_\sigma(L) := \sigma \sqrt{200C(0) \ln(L) \ln(2^{2(d+1)}L^e)} \quad (5.21)$$

and set $\varepsilon(L) := -E_\sigma(L) - \Delta E$ with some $\Delta E > 0$ fixed, but arbitrary. Let $\omega \in \Omega$ such that the inequality

$$\sup_{y \in A_L(x)} \{|V^{(\omega)}(y)|\} \leq E_\sigma(L) \quad (5.22)$$

is satisfied. Then, Lemma 3.5 and the Combes–Thomas Lemma A.1 imply the estimate for all $E \leq \varepsilon(L)$

$$\sup_{\eta > 0} \|R_{B_N^L(x), B_0^L(x)}(V^{(\omega)}, E + i\eta)\| \leq (L \sqrt{v_0^{(\omega)} - E})^{-r} g(L \sqrt{v_0^{(\omega)} - E}) \quad (5.23)$$

Here, $v_0^{(\omega)} := \inf_{y \in A_L(x)} \{V^{(\omega)}(y)\}$ and we have defined a function g on \mathbb{R} by

$$g(z) := c_N z^{r+(d-3)/2} \left(1 + \frac{d^2}{8\tilde{c}_N z}\right) \exp\{-\tilde{c}_N z\} \quad (5.24)$$

with suitable constants $c_N, \tilde{c}_N < \infty$ depending only on N . Observe that there exists $L_0 \equiv L_0(N, r_0, \Delta E)$ such that g satisfies the inequality

$$g(\tilde{L} \sqrt{\Delta E}) \leq (\Delta E)^{r/2} \tag{5.25}$$

for all $\tilde{L} \geq L_0$ and all $0 < r < r_0$. Clearly, (5.25) also holds with $\tilde{L} = L \sqrt{(v_0^{(\omega)} - E)/\Delta E}$, if $L \geq L_0$ and $E \leq \varepsilon(L)$, because $v_0^{(\omega)} - E \geq \Delta E$ for all ω obeying (5.22). Therefore we have (r, E, L, x) -regularity of $V^{(\omega)}$ under this condition. But according to Lemma 5.3 the probability of the event (5.22) is, independently of x , at least $1 - L^{-e}$ provided $L \geq \ell_H$. The proof is completed by setting $L_H := \max\{\ell_H, L_0\}$. ■

Lemma 5.6 (Weak Disorder). Let $\varrho, r_0 > 0, 0 < r < r_0$ and $N \in \mathbb{N}$ be given and assume that the Gaussian random potential V with covariance function $x \mapsto \sigma^2 C(x)$ has property (H). Then, for every given energy $-\infty < E_0 < 0$ there is a length $0 < L_H < \infty$ such that for every $L \geq L_H$ one can find $\sigma(L) > 0$ with

$$\mathbb{P}\{\omega : V^{(\omega)} \text{ is } (r, E, L, x)\text{-regular}\} \geq 1 - L^{-e} \tag{5.26}$$

for all $E \in]-\infty, E_0]$, all $x \in \mathbb{R}^d$ and all $\sigma \in]0, \sigma(L)]$. The length L_H depends on N, r_0, E_0 and on the Hölder exponent and the size of the neighbourhood referred to in property (H).

Proof. Given $-\infty < E_0 < 0$ and $\sigma > 0$, set $\Delta E := -E_0/2$ and $E_\sigma(L)$ as in (5.21). As in the proof of Lemma 5.5 we infer the existence of a finite length $L_H := \max\{\ell_H, L_0(N, r_0, -E_0/2)\}$, which is independent of σ , such that the inequality (5.26) holds for all $E \leq -E_\sigma(L) + E_0/2$. The proof is completed by requiring $E_\sigma(L) \leq -E_0/2$, that is $\sigma \leq \sigma(L)$ with

$$\sigma(L) := -(E_0/2)[200C(0) \ln(L) \ln(2^{2(d+1)}L^e)]^{-1/2} \quad \blacksquare \tag{5.27}$$

Remarks 5.7. (i) The low-energy initial estimate, Lemma 5.5, could have also been obtained by using the Wegner estimate (2.15) together with the decay of $W(E)$ for $E \rightarrow -\infty$ instead of the Combes–Thomas estimate (A.1). But this would require property (P) in addition to property (H). In any case, we would not know how to derive the weak-disorder initial estimate without the Combes–Thomas estimate.

(ii) The reason why we are not able to prove a strong-disorder initial estimate is that controlling the frame operator (3.4) with Lemma 3.5 requires a control of the excursions of the random potential V to extremely

negative energies. But these unwanted events occur with increasing probability if the disorder is increased, see the exact asymptotics (5.19). A subsequent application of the Wegner estimate (2.15) instead of the Combes–Thomas estimate would not cure the situation either, because our Wegner constant (2.13) does not vanish in the strong-disorder limit.

5.3. Controlling Long-Range Correlations

In this subsection we are concerned with Assumption (iii) of Theorem 3.14, which ensures that sufficiently spatially separated events are sufficiently decorrelated. We will distinguish the two different cases whether the random potential V has property (M) or property (R).

In case of property (M) we will apply Theorem 3.14 with $V_k = V$ for all $k \in \mathbb{N}_0$ in Subsection 5.4 below. For this purpose we will need

Lemma 5.8. Let V be a Gaussian random potential on \mathbb{R}^d with property (M) and put $\vartheta_0 := \nu/2 + (2/\delta)(d-1)(\nu-1) < 1$. Then, for all integers $2 \leq K \leq K_0$, all $\vartheta_0 < \vartheta < 1$ and all $\varrho > 0$ obeying

$$(4/K)(d-1)(\nu-1)/(2\vartheta-\nu) < \varrho \leq \delta/K \quad (5.28)$$

there exists a finite length $L_M > 0$ such that the random potential V is $(K, L, \varrho, \vartheta)$ -independent in the sense of Definition 3.12 for all $L > L_M$. The length L_M depends on K, ϑ and ν .

Remark 5.9. For Lemma 5.8 to hold it is irrelevant whether V is Gaussian or not.

Proof of Lemma 5.8. Let $N \in \mathbb{N}$ and let A, ν, K_0 and δ as in property (M). By Definition 2.2 of the strong-mixing coefficient we have for all integers $2 \leq K \leq K_0$ and all $A_k \in \mathcal{A}_V(A_k)$, $k = 1, \dots, K$, with $|A_k| \leq (L/N)^{d/\nu}$ and $\text{dist}_\infty(A_k, A_{k'}) \geq L/(4N)$ for $k \neq k'$ that

$$\mathbb{P}\left(\bigcap_{k=1}^K A_k\right) \leq \mathbb{P}(A_1) \mathbb{P}\left(\bigcap_{k=2}^K A_k\right) + \alpha_\nu(L/(4N), (K-1)(L/N)^{d/\nu}) \quad (5.29)$$

Iterating this inequality and using $\mathbb{P}(A_k) \leq (L/N)^{-d/\nu}$, where $\varrho > 0$ as required in Definition 3.12, we obtain

$$\mathbb{P}\left(\bigcap_{k=1}^K A_k\right) \leq (L/N)^{-Kd/\nu} + \alpha_\nu(L/(4N), (K-1)(L/N)^{d/\nu}) \sum_{k=0}^{K-2} (L/N)^{-kd/\nu} \quad (5.30)$$

The k -sum is bounded from above by $K - 1$ for $L \geq N$ and property (M) yields for all $\varrho \leq \delta/K$

$$\mathbb{P} \left(\bigcap_{k=1}^K A_k \right) \leq [1 + (K - 1) A] (L/N)^{-K\varrho/v} \tag{5.31}$$

Since $\delta > 4(d - 1)(v - 1)/(2 - v)$, inequality (5.28) is satisfied for all $\vartheta_0 < \vartheta < 1$ and (3.30) of Definition 3.12 holds for all $L > L_M := N[1 + (K - 1) A]^{v/[K\varrho(1 - \vartheta)]}$. ■

In case of property (R) we now construct a sequence $\{V_k\}_{k \in \mathbb{N}_0}$ of Gaussian random potentials such that V_k satisfies Assumption (iii) of Theorem 3.14 on the length scale L_k and converges suitably to V .

Lemma 5.10. For $N \geq 4$ integer and a monotone increasing sequence $\{L_k\}_{k \in \mathbb{N}_0}$ of length scales with $L_0 > 8N$ and $\lim_{k \rightarrow \infty} L_k = \infty$ define the box $B_k := (A_{L_k/(4N)}(0), 1)$ and set $B_\infty := (\mathbb{R}^d, 0)$. Let V be a Gaussian random potential on \mathbb{R}^d with property (R). Then there exist Gaussian random potentials $V_k: \Omega \times \mathbb{R}^d \rightarrow \mathbb{R}$, $(\omega, x) \mapsto V_k^{(\omega)}(x)$, with covariance functions

$$x \mapsto C_k(x) := \mathbb{E}\{V_k(x) V_k(0)\} := \int_{\mathbb{R}^d} d^d y \gamma_k(y) \gamma_k(x + y) \tag{5.32}$$

where $\gamma_k := \gamma_{\chi_{B_k}}$, such that for all $k \in \mathbb{N}_0$

- (i) $0 < C_0(0) \leq C_k(0) \leq C_{k'}(0) \leq C(0)$ for all $k' \geq k$,
- (ii) V_k has property (H) uniformly in k with the same Hölder exponent and the same neighbourhood as V ,
- (iii) V_k is $(K, L_k, \varrho, \vartheta)$ -independent in the sense of Definition 3.12 for all $K \geq 2$ integer, $\varrho > 0$ and $0 < \vartheta \leq 1$,
- (iv)

$$\mathbb{P}\{\omega : \sup_{x \in A_L(0)} |V_k^{(\omega)}(x) - V_{k'}^{(\omega)}(x)| \geq E\} \leq 2^{2(d+1)} \exp \left\{ -\frac{E^2 L_k^{2\zeta - d}}{\tilde{\gamma} \ln L} \right\} \tag{5.33}$$

for all $k \leq k' \leq \infty$, all $E \geq 0$ and all $L \geq \tilde{L}$. Here we have set $V_\infty := V$, and $\tilde{\gamma}$ and \tilde{L} are some strictly positive constants which are independent of k and k' .

Remark 5.11. It follows from (5.38) below that $V_k(x)$ converges for all $x \in \mathbb{R}^d$ to $V(x)$ in \mathbb{P} -mean-square sense. Moreover, assertion (iv) of

the lemma implies that V_k converges also uniformly in x on bounded cubes to V in probability.

Proof of Lemma 5.10. We denote the Fourier (–Plancherel) transform of $f \in L^2(\mathbb{R}^d)$ by $\hat{f}: \mathbb{R}^d \ni q \mapsto \hat{f}(q) := (2\pi)^{-d/2} \int_{\mathbb{R}^d} d^d x e^{-iq \cdot x} f(x)$. The matrix-valued function $\mathbb{R}^d \ni x \mapsto \mathbf{D}(x)$ with matrix elements

$$\mathbf{D}_{k,k'}(x) := \int_{\mathbb{R}^d} d^d q e^{iq \cdot x} |\hat{\gamma}_k(q)| |\hat{\gamma}_{k'}(q)|, \quad k, k' \in \mathbb{N}_0 \cup \{\infty\} \quad (5.34)$$

is continuous in x due to $|\hat{\gamma}_k| |\hat{\gamma}_{k'}| \in L^1(\mathbb{R}^d)$, which follows from $\gamma_k \in L^2(\mathbb{R}^d)$ and thus $\hat{\gamma}_k \in L^2(\mathbb{R}^d)$. Each $\mathbf{D}_{k,k'}$ is a real-valued and even function in x , because $|\hat{\gamma}_k(q)|^2 = \hat{\gamma}_k(q) \hat{\gamma}_k(-q)$. Moreover, since each $\mathbf{D}_{k,k'}$ has a non-negative Fourier transform which factorizes in k and k' , the Bochner–Khinchine theorem implies that $x \mapsto \mathbf{D}(x)$ is a matrix-valued covariance function. Therefore—see e.g., Thm. 4.2 in [Li] or Appendix A.4 to Part I of [GJ]—there exists a sequence $\{V_k\}_{k \in \mathbb{N}_0 \cup \{\infty\}}$ of *jointly* Gaussian homogeneous random fields on some complete probability space $(\Omega', \mathcal{A}', \mathbb{P}')$ with zero mean and covariance $\mathbb{E}\{V_k(x) V_{k'}(0)\} = \mathbf{D}_{k,k'}(x)$. Without loss of generality we assume that the original probability space $(\Omega, \mathcal{A}, \mathbb{P})$ underlying V coincides with $(\Omega', \mathcal{A}', \mathbb{P}')$. The same arguments as in the proof of Lemma 2.8 show that each V_k has a separable and jointly measurable version. We only consider these versions. Since the non-negative function γ is determined by (2.10) only up to Euclidean translations, we can assume without loss of generality that $\gamma(0) > 0$. Thus we have $0 < C_k(0) \leq C(0)$ for the covariance function $C_k(x) := \mathbf{D}_{k,k}(x)$ of V_k for all $k \in \mathbb{N}_0 \cup \{\infty\}$. Moreover, the sequence $\{C_k(x)\}_{k \in \mathbb{N}_0}$ is increasing for all $x \in \mathbb{R}^d$. This proves that $\{V_k\}_{k \in \mathbb{N}_0}$ is a sequence of Gaussian random potentials on \mathbb{R}^d in the sense of Definition 2.6 whose covariance functions satisfy assertion (i) of the lemma. In particular, the relation $C_\infty = C$ allows one to identify V_∞ and V .

As to Assertion (ii), we remark that for all $k \in \mathbb{N}_0$ an indicator function $\chi_{B_k} \in \mathcal{C}_0^\infty(\mathbb{R}^d)$ of the box B_k is uniformly Hölder continuous with exponent one,

$$|\chi_{B_k}(x+y) - \chi_{B_k}(x)| \leq d\kappa_1 |y|_\infty \quad \text{for all } x, y \in \mathbb{R}^d \quad (5.35)$$

as a consequence of the mean-value theorem and the boundedness (3.1). Note that the constant κ_1 does not depend on k . Therefore we get, uniformly in k ,

$$|\gamma_k(x+y) - \gamma_k(x)| \leq (\gamma_0 d\kappa_1 \sup_{y \in U} \{|y|_\infty^{1-\alpha}\} + a) |y|_\infty^\alpha \quad (5.36)$$

for all $x \in \mathbb{R}^d$ and all $y \in U$, the neighbourhood of the origin referred to in property (R) for V . Hence, γ_k is uniformly Hölder continuous for all $k \in \mathbb{N}_0$

with the same exponent α and the same neighbourhood of the origin as given for γ .

Assertion (iii) follows from $\gamma_k(x) = 0$ for all $|x|_\infty \geq L_k/(8N)$. Hence, $C_k(x) = 0$ for all $|x|_\infty \geq L_k/(4N)$ by (5.32), and the Gaussian nature of V_k implies the stochastic independence of events which are at least a distance $L_k/(4N)$ apart.

Assertion (iv) will be deduced from an application of Lemma 5.3 to the left-hand side of (5.33). To this end observe that by construction the difference $V_k - V_{k'}$ is also a Gaussian random potential on \mathbb{R}^d for all $k, k' \in \mathbb{N}_0 \cup \{\infty\}$. Its covariance function

$$\mathbb{E}\{(V_k(x) - V_{k'}(x))(V_k(0) - V_{k'}(0))\} = C_k(x) + C_{k'}(x) - 2\mathbf{D}_{k, k'}(x) \tag{5.37}$$

has property (H) with the same Hölder exponent α and the same neighbourhood as given for the covariance function of V . This follows from assertion (ii) and $\mathbf{D}_{k, k'}(0) - \mathbf{D}_{k, k'}(x) \geq 0$ for all $x \in \mathbb{R}^d$. Moreover, since the Fourier transformation is an isometry on $L^2(\mathbb{R}^d)$, we conclude for $k < k'$ the inequality

$$\mathbb{E}\{(V_k(0) - V_{k'}(0))^2\} \leq \|(\widehat{\gamma_k - \gamma_{k'}})\|^2 = \|\gamma_k - \gamma_{k'}\|^2 \leq \frac{\tilde{\gamma}}{200} L_k^{d-2\zeta} \tag{5.38}$$

with some k, k' -independent constant $0 < \tilde{\gamma} < \infty$ and ζ taken from property (R). Hence, (5.33) follows from Lemma 5.3 for all $L \geq \tilde{L} = \ell_H$ with \tilde{L} being also independent of k and k' due to the uniform Hölder property (ii) of $V_k - V_{k'}$. ■

5.4. Proof of Theorem 5.1

We are now in a position to prove Theorem 5.1. This proof also completes the proof of the main Theorem 2.12.

Proof of Theorem 5.1. We show that Theorem 5.1 follows from an application of Theorem 3.14. To do so we have to check the assumptions of this theorem.

Let $N = 4$ and $S = 2$. Choose the exponents ν and r such that

$$1 < \nu < 1 + \frac{1}{8d} \tag{5.39}$$

$$4d\nu < r < 4d + \frac{1}{2} =: r_0 \tag{5.40}$$

in accordance with (5.1) and (5.2). The precise value of ν will be fixed later on. In case that V has properties (P), (H) and (M)—let us call this simply case (PHM)—we set $V_k = V$ for all $k \in \mathbb{N}_0$. In case that V has property (R) we use the sequence of Gaussian random potentials constructed in Lemma 5.10 for the sequence (3.38) of length scales L_k . For the low-energy assertion (i) of Theorem 5.1 we consider $\sigma > 0$ arbitrary, but fixed, and set $I_k =]-\infty, \varepsilon(L_k)]$ in Theorem 3.14, $\varepsilon(L)$ being the energy defined in Lemma 5.5 and given explicitly below (5.21). For the weak-disorder assertion (ii) of Theorem 5.1 we set $I_k =]-\infty, E_0]$ for all $k \in \mathbb{N}_0$, but allow only for disorder strengths $\sigma \in]0, \sigma(L_k)]$ on the length scale L_k with $\sigma(L)$ given by (5.27) in the proof of Lemma 5.6. For the time being we suppose that the initial length satisfies $L_0 > \max\{2^{2/(\nu-1)}, L_H, L_M\}$. The length L_H is to be taken from Lemma 5.5 for the low-energy assertion, respectively from Lemma 5.6 for the weak-disorder assertion. The length L_M was defined in Lemma 5.8.

Hence, considering case (PHM), we conclude that Lemma 5.5, respectively Lemma 5.6, provides the Initial-Estimate Assumption 3.14(v) for assertion (i), respectively assertion (ii), of Theorem 5.1 for any $0 < r < r_0$ and $\varrho > 0$. The same is true for case (R), because Lemma 5.10(i) and (ii) ensure that Lemmas 5.5 and 5.6 remain true with the same constants L_H , $\varepsilon(L)$ and $\sigma(L)$ of case (PHM), if V is replaced by V_k .

Next we come to Assumptions 3.14(ii) and (iii). First, we consider the case (PHM) and fix ν as required by property (M). Obviously, both assumptions then follow from Lemma 5.8 with $K = N - S = 2$. Moreover, observing (5.39) and choosing $\vartheta > \max\{3/4, \vartheta_0\}$, the left inequality in (5.28) guarantees that Assumptions 3.14(ii) and (iii) hold for some

$$\varrho < 1/2 \tag{5.41}$$

Concerning case (R), Assumption 3.14(iii) holds for all $0 < \vartheta \leq 1$ and all $\varrho > 0$ by Lemma 5.10(iii). Thus we may also pick ν , ϱ and ϑ as in case (PHM), thereby satisfying Assumption 3.14(ii) and (5.41).

Taking into account (5.39) and (5.40), it follows that a sufficient condition for Assumption 3.14(i) to hold is

$$w < d - 1/4 \tag{5.42}$$

We will show below that in case (PHM) Assumption 3.14(iv) is satisfied for all ϱ , $w > 0$ which obey

$$w > \varrho + d + 1 - \frac{2}{\nu} \tag{5.43}$$

We will also show below that Assumption 3.14(iv) is satisfied in case (R) if in addition to (5.43) the inequality

$$\zeta > \frac{d}{2} + r + 2w + \frac{2}{\nu} - 1 \tag{5.44}$$

is assumed for the exponent ζ . Since Assumptions 3.14(ii) and (iii) can be fulfilled for some $\varrho < 1/2$ and since ν obeys (5.39), it follows that (5.42) and (5.43) are compatible. Moreover, since property (R) requires $\zeta > 13d/2 + 1$, the condition (5.44) does not impose a further restriction beyond (5.39), (5.40) and (5.42). Up to now we have shown that Assumptions 3.14(i), (ii), (iii) and (v) can be satisfied under the conditions (5.43) and (5.44). Thus, in order to complete the proof it remains to show that (5.43) and (5.44) are sufficient conditions for Assumption 3.14(iv) to hold.

We consider both cases (PHM) and (R) simultaneously. Since $V_k = V$ for all k in case (PHM), there is less to prove in case (PHM) than in case (R). Let $E \in I_0$, $x \in \mathbb{R}^d$ and $U = V$ or $U = V_{k+1}$. Then, the inequality

$$\begin{aligned} & \mathbb{P}\{\omega : V_k^{(\omega)} \text{ is } (w, E, L_k, x)\text{-non-resonant and an} \\ & \quad (r, E, L_k, x)\text{-approximation of } U^{(\omega)}\} \\ & \geq \mathbb{P} \left\{ \omega : \Phi_{B_n^{L_k(x)}}(E - V_k^{(\omega)}) < g_n \text{ for all } 1 \leq n \leq 4 \right. \\ & \quad \text{and } \text{dist}(E, \text{spec}(H_{A_n L_k/4(x)}(V_k^{(\omega)}))) \geq g_n L_k^{-w} \text{ for all } 1 \leq n \leq 4 \\ & \quad \text{and } \text{dist}(E, \text{spec}(H_{A_{L_k}(x)}(U^{(\omega)}))) \geq L_k^{-w'} \\ & \quad \left. \text{and } \|V_k^{(\omega)} - U^{(\omega)}\|_{\infty; A_{L_k}(x)} \left(L_k^w + \frac{16\sqrt{2}\kappa_1}{L_k\sqrt{g_4}} L_k^{w/2} \right) \leq \frac{L_k^{-w'-r}}{2} \right\} \end{aligned} \tag{5.45}$$

is valid for all $w' > 0$ and all $g_n > 0$, $n = 1, \dots, 4$. It follows from Definition 3.8, Definition 3.10 and the inequalities

$$\|R_{B_n^{L_k(x)}, B_0^{L_k(x)}}(V_k, E + i\eta)\| \leq \Phi_{B_n^{L_k(x)}}(E - V_k) \|(H_{A_n L_k/4(x)}(V_k) - E)^{-1}\| \tag{5.46}$$

$$\|W_{B_n^{L_k(x)}, B_4^{\ell_k}(y)}(V_k, E + i\eta)\| \leq \Phi_{B_n^{L_k(x)}}(E - V_k) \|(H_{A_n L_k/4(x)}(V_k) - E)^{-1}\| \tag{5.47}$$

$$\begin{aligned}
\|D_x^{L_k}(U, V_k, E + i\eta)\| &\leq \|V_k - U\|_{\infty; A_{L_k}(x)} \| (H_{A_{L_k}(x)}(U) - E)^{-1} \| \\
&\times \left\{ \Phi_{B_4^{L_k}(x)}(E - V_k) \| (H_{A_{L_k}(x)}(V_k) - E)^{-1} \| \right. \\
&\quad \left. + \frac{16\sqrt{2}\varkappa_1}{L_k} \| (H_{A_{L_k}(x)}(V_k) - E)^{-1} \|^{1/2} \right\}
\end{aligned} \tag{5.48}$$

where $1 \leq n < n' \leq 4$, $y \in T_n^{L_k}(x)$, $\ell_k := (L_k/4)^{1/\nu}$. To derive the latter three inequalities Lemma 3.5 and (3.11) have been used. Note that in case (PHM) the last two lines of (5.45) have simply to be omitted. Since $\mathbb{P}(A \cap B) \geq \mathbb{P}(A) - \mathbb{P}(\Omega \setminus B)$ for $A, B \in \mathcal{A}$, we bound the right-hand side of (5.45) from below by

$$\begin{aligned}
&\mathbb{P}\{\omega : \Phi_{B_n^{L_k}(x)}(E - V_k^{(\omega)}) < g_n \text{ for all } 1 \leq n \leq 4\} \\
&- \sum_{n=1}^4 \mathbb{P}\{\omega : \text{dist}(E, \text{spec}(H_{A_{nL_k/4}(x)}(V_k^{(\omega)}))) < g_n L_k^{-w}\} \\
&- \mathbb{P}\{\omega : \text{dist}(E, \text{spec}(H_{A_{L_k}(x)}(U^{(\omega)}))) < L_k^{-w'}\} \\
&- \mathbb{P}\left\{\omega : \|V_k^{(\omega)} - U^{(\omega)}\|_{\infty; A_{L_k}(x)} > \frac{L_k^{-(w'+w+r)}}{2} \left(1 + \frac{16\sqrt{2}\varkappa_1}{L_k^{1+w/2}\sqrt{g_4}}\right)^{-1}\right\}
\end{aligned} \tag{5.49}$$

Choosing $g_n = \Phi_{B_n^{L_k}(x)}(E - v_0(L_k))$ with

$$v_0(L) := -\sigma \sqrt{200C(0) \ln(L) \ln(2^{2(d+2)}L^e)} \tag{5.50}$$

the first probability in (5.49) is seen to be bounded from below by $\mathbb{P}\{\omega : \|V_k^{(\omega)}\|_{\infty; A_{L_k}(x)} < -v_0(L_k)\} \geq 1 - L_k^{-e}/4$ by virtue of Lemma 5.3. The probabilities in the second and third line of (5.49) are estimated from above with the Wegner bound (2.15) and the last probability is estimated from above with Lemma 5.10(iv). Thus, (5.49) is bounded from below by

$$\begin{aligned}
&1 - \frac{L_k^{-e}}{4} - 2W_0 \sum_{n=1}^4 \left(\frac{n}{4}\right)^d g_n L_k^{d-w} - 2W_0 L_k^{d-w'} \\
&- 2^{2(d+1)} \exp\left\{-\frac{L_k^{2(\zeta-d/2-w'-w-r)}}{4\tilde{\gamma} \ln L_k} \left(1 + \frac{16\sqrt{2}\varkappa_1}{L_k^{1+w/2}\sqrt{g_4}}\right)^{-2}\right\}
\end{aligned} \tag{5.51}$$

The constant $W_0 > 0$ is an upper bound on the arising Wegner constants which is uniform in k due to Lemma 5.10(i), (2.13) and because the subset

$\{E + g_n L_k^{-w} + L_k^{-w'} : E \in I_0, 1 \leq n \leq 4, k \in \mathbb{N}_0\}$ of the real line has a finite supremum. The latter is true because of (5.39) and the estimate

$$g_n = \Phi_{B_n^{L_k(x)}}(E - v_0(L_k)) \leq \frac{16^2}{(L_k/4)^{2/\nu}} \left(\frac{\kappa_2}{2} + \sqrt{\frac{\kappa_4}{2} + 2 \frac{L_k^2 \kappa_1^2}{16^2} |v_0(L_k)|} \right) \tag{5.52}$$

where we have used the definition (3.14) of the functional Φ . Again by (3.14), it follows that

$$\sqrt{g_4} \geq 16 \sqrt{\kappa_2/2} L_k^{-1} \tag{5.53}$$

Combining the inequalities (5.45), (5.49) and (5.51), choosing $w' = w - 1 + 2/\nu$ and observing (5.52), (5.53), (5.43) and (5.44), we infer the existence of a finite length $L_R > 0$ such that

$$\begin{aligned} \mathbb{P}\{\omega : V_k^{(\omega)} \text{ is } (w, E, L_k, x)\text{-non-resonant and} \\ \text{an } (r, E, L_k, x)\text{-approximation of } U^{(\omega)}\} \geq 1 - L_k^{-e} \end{aligned} \tag{5.54}$$

for all $L_k > L_R$. This establishes Assumption 3.14(iv) and thus completes the proof of the theorem. \blacksquare

APPENDIX. AN EXPLICIT COMBES–THOMAS ESTIMATE

The initial estimates of the multi-scale analysis are obtained in Subsection 5.2 with the help of a norm estimate for the “localized” finite-volume resolvent at energies below the bottom of the spectrum. In the literature such type of estimates go with the names of J.-M. Combes and L. E. Thomas [CT], see also [BCH2] and [St].

Lemma A.1. Let $v \in L^\infty(A)$ be a bounded potential on the bounded open cube $A \subset \mathbb{R}^d$. Let $A_1, A_2 \subset A$ be disjoint Borel subsets of A such that $\delta := \text{dist}(A_1, A_2) > 0$ and let $f_j : A \rightarrow [0, 1]$ be a measurable function with support in A_j for $j = 1, 2$. Then one has for all $E < v_0 := \text{ess inf}_{x \in A} \{v(x)\}$ the inequality

$$\begin{aligned} \|f_1(H_A(v) - E)^{-1} f_2\| &\leq \frac{\sqrt{|A_1| |A_2|}}{2^{(d+1)/4} (\pi \delta)^{(d-1)/2}} (v_0 - E)^{(d-3)/4} \\ &\quad \times \left(1 + \frac{d^2}{8\delta \sqrt{2(v_0 - E)}} \right) \exp\{-\delta \sqrt{2(v_0 - E)}\} \end{aligned} \tag{A.1}$$

where $H_A(v)$ is defined on $L^2(A)$ as in (2.5).

Proof. Let $\varphi \in L^2(\Lambda)$. From the Feynman–Kac–Itô representation of the Schrödinger semigroup $e^{-tH_A(v)}$, $t > 0$, see e.g., [BHL2], and the explicit form of the heat kernel one obtains the inequality

$$\begin{aligned} & \|f_1 e^{-tH_A(v)} f_2 \varphi\|^2 \\ & \leq e^{-2tv_0} \int_{\mathbb{R}^d} d^d x (f_1(x))^2 \left(\int_{\mathbb{R}^d} d^d y \frac{e^{-(x-y)^2/(2t)}}{(2\pi t)^{d/2}} f_2(y) |\varphi(y)| \right)^2 \end{aligned} \quad (\text{A.2})$$

The fact that f_1 and f_2 are supported in spatially separated regions allows one to bound the right-hand side of (A.2) by

$$e^{-2tv_0} \frac{e^{-\delta^2/t}}{(2\pi t)^d} \|f_1\|^2 \langle f_2, |\varphi| \rangle^2 \quad (\text{A.3})$$

Estimating the scalar product by the Schwarz inequality and observing $\|f_j\|^2 \leq |A_j|$, we conclude for the operator norm

$$\|f_1 e^{-tH_A(v)} f_2\| \leq \sqrt{|A_1| |A_2|} \frac{e^{-tv_0} e^{-\delta^2/(2t)}}{(2\pi t)^{d/2}} \quad (\text{A.4})$$

Therefore, by Laplace transforming $e^{-tH_A(v)}$ with respect to t , we get the inequality

$$\begin{aligned} & \|f_1 (H_A(v) - E)^{-1} f_2\| \\ & \leq \frac{2^{1/2+d/4} \sqrt{|A_1| |A_2|}}{(2\pi)^{d/2}} \left(\frac{\delta}{\sqrt{v_0 - E}} \right)^{1-d/2} K_{1-d/2}(\delta \sqrt{2(v_0 - E)}) \end{aligned} \quad (\text{A.5})$$

where $E < v_0$, K_ν denotes the modified Bessel function of the second kind with index ν , and formula 3.471.9 in [GR] has been used. Upon inserting the series expansion 8.451.6 in [GR] for K_ν , truncating it after the zeroth term and estimating the remainder, we arrive at (A.1). ■

ACKNOWLEDGMENTS

We would like to express our gratitude to Jean-Marie Barbaroux, Kurt Broderix,[†] Jean-Michel Combes, Peter Hislop, Dirk Hundertmark, Thomas Hupfer, Werner Kirsch, Peter Stollmann, Günter Stolz and Simone Warzel, with whom we enjoyed fruitful and stimulating discussions. H.L. is grateful to Ilya Ya. Goldsheid for encouraging him to continue research on this project. W.F. thanks Jean-Michel Combes for hospitality and support at the Centre de Physique Théorique, CNRS, Marseille and at the Université de Toulon et du Var. P.M. gratefully acknowledges Annette Zippelius for travel support. This work was supported by the Deutsche Forschungsgemeinschaft under grant nos. Le 330/10-1 and Le 330/12-1.

The latter is a project within the Schwerpunktprogramm “Interagierende stochastische Systeme von hoher Komplexität.”

REFERENCES

- [Ad] R. J. Adler, *The Geometry of Random Fields* (Wiley, Chichester, 1981).
- [Ai] M. Aizenman, Localization at weak disorder: Some elementary bounds, *Rev. Math. Phys.* **6**:1163–1182 (1994).
- [An] P. W. Anderson, Absence of diffusion in certain random lattices, *Phys. Rev.* **109**:1492–1505 (1958).
- [AG] M. Aizenman and G. M. Graf, Localization bounds for an electron gas, *J. Phys. A* **31**:6783–6806 (1998).
- [AM] M. Aizenman and S. Molchanov, Localization at large disorder and at extreme energies: An elementary derivation, *Commun. Math. Phys.* **157**:245–278 (1993).
- [Abs] M. Abramowitz and I. A. Stegun, *Handbook of Mathematical Functions with Formulas, Graphs and Mathematical Tables*, ninth printing (Dover Publications, New York, 1972).
- [AiS] M. Aizenman and B. Simon, Brownian motion and Harnack inequality for Schrödinger operators, *Commun. Pure Appl. Math.* **35**:209–273 (1982).
- [ASFH] M. Aizenman, J. H. Schenker, R. M. Friedrich, and D. Hundertmark, Finite-volume criteria for Anderson localization, e-print math-ph/9910022 (1999), to appear in *Commun. Math. Phys.*
- [Bel] Yu. K. Belyaev, Analytic random processes, *Theory Prob. Applications* **4**:402–409 (1959) [Russian original: *Teor. Ver. Primen.* **4**:437–444 (1959)].
- [Ber] S. M. Berman, The maximum of a Gaussian process with nonconstant variance, *Ann. Inst. Henri Poincaré, Probab. Stat.* **21**:383–391 (1985).
- [BCH1] J.-M. Barbaroux, J. M. Combes, and P. D. Hislop, Landau Hamiltonians with unbounded random potentials, *Lett. Math. Phys.* **40**:355–369 (1997).
- [BCH2] J. M. Barbaroux, J. M. Combes, and P. D. Hislop, Localization near band edges for random Schrödinger operators, *Helv. Phys. Acta* **70**:16–43 (1997).
- [BCM] J. M. Barbaroux, J. M. Combes, and R. Montcho, Remarks on the relation between quantum dynamics and fractal spectra, *J. Math. Anal. Appl.* **213**:698–722 (1997).
- [BEEK +] V. L. Bonch-Bruевич, R. Enderlein, B. Esser, R. Keiper, A. G. Mironov, and I. P. Zvyagin, *Elektronentheorie ungeordneter Halbleiter* (VEB Deutscher Verlag der Wissenschaften, Berlin, 1984) [Russian original: (Nauka, Moscow, 1981)].
- [BFM] J. M. Barbaroux, W. Fischer, and P. Müller, Dynamical properties of random Schrödinger operators, e-print math-ph/9907002 (1999).
- [BG] A. Boutet de Monvel and V. Grinshpun, Exponential localization for multi-dimensional Schrödinger operator with random point potential, *Rev. Math. Phys.* **9**:425–451 (1997).
- [BHL1] K. Broderix, D. Hundertmark, and H. Leschke, Self-averaging, decomposition and asymptotic properties of the density of states for random Schrödinger operators with constant magnetic field, in *Path Integrals from meV to MeV: Tutzing '92*, H. Grabert, A. Inomata, L. S. Schulman, and U. Weiss, eds. (World Scientific, Singapore, 1993), pp. 98–107.
- [BHL2] K. Broderix, D. Hundertmark, and H. Leschke, Continuity properties of Schrödinger semigroups with magnetic fields, *Rev. Math. Phys.* **12**:181–225 (2000).
- [BS] D. Buschmann and G. Stolz, Two-parameter spectral averaging and localization for non-monotonous random Schrödinger operators (1998), to appear in *Trans. Amer. Math. Soc.*

- [CFKS] H. L. Cycon, R. G. Froese, W. Kirsch, and B. Simon, *Schrödinger Operators* (Springer, Berlin, 1987).
- [CH1] J.-M. Combes and P. D. Hislop, Localization for some continuous, random Hamiltonians in d -dimensions, *J. Funct. Anal.* **124**:149–180 (1994).
- [CH2] J. M. Combes and P. D. Hislop, Landau Hamiltonians with random potentials: Localization and the density of states, *Commun. Math. Phys.* **177**:603–629 (1996).
- [CHM] J. M. Combes, P. D. Hislop, and E. Mourre, Correlated Wegner inequalities for random Schrödinger operators, *Contemporary Mathematics* **217**:191–203 (1998).
- [CL] R. Carmona and J. Lacroix, *Spectral Theory of Random Schrödinger Operators* (Birkhäuser, Boston, 1990).
- [CT] J. M. Combes and L. Thomas, Asymptotic behaviour of eigenfunctions for multi-particle Schrödinger operators, *Commun. Math. Phys.* **34**:251–270 (1973).
- [D] P. Doukhan, *Mixing, Properties and Examples* (Springer, New York, 1994).
- [DK1] H. von Dreifus and A. Klein, A new proof of localization in the Anderson tight binding model, *Commun. Math. Phys.* **124**:285–299 (1989).
- [DK2] H. von Dreifus and A. Klein, Localization for random Schrödinger operators with correlated potentials, *Commun. Math. Phys.* **140**:133–147 (1991).
- [DLS] F. Delyon, Y. Lévy, and B. Souillard, Anderson localization for multi-dimensional systems at large disorder or large energy, *Commun. Math. Phys.* **100**:463–470 (1985).
- [DMP1] T. C. Dorlas, N. Macris, and J. V. Pulé, Localisation in a single-band approximation to random Schrödinger operators in a magnetic field, *Helv. Phys. Acta* **68**:329–364 (1995).
- [DMP2] T. C. Dorlas, N. Macris, and J. V. Pulé, Localization in single Landau bands, *J. Math. Phys.* **37**:1574–1595 (1996).
- [DMP3] T. C. Dorlas, N. Macris, and J. V. Pulé, Characterization of the spectrum of the Landau Hamiltonian with delta impurities, *Commun. Math. Phys.* **204**:367–396 (1999).
- [DS] D. Damanik and P. Stollmann, Multi-scale analysis implies strong dynamical localization, e-print math-ph/9912002 (1999), to appear in *Geom. Funct. Anal.*
- [E] K. Efetov, *Supersymmetry in Disorder and Chaos* (Cambridge University Press, Cambridge, 1997).
- [F] X. Fernique, Régularité des trajectoires des fonctions aléatoires Gaussiennes, in *Ecole d'Été de Probabilités de Saint-Flour IV–1974*, Lecture Notes in Mathematics, Vol. 480, P.-L. Hennequin, ed. (Springer, Berlin, 1975), pp. 1–96.
- [FHLM1] W. Fischer, T. Hupfer, H. Leschke, and P. Müller, Rigorous results on Schrödinger operators with certain Gaussian random potentials in multi-dimensional continuous space, in *Differential Equations, Asymptotic Analysis, and Mathematical Physics*, M. Demuth and B.-W. Schulze, eds. (Akademie, Berlin, 1997), pp. 105–112.
- [FHLM2] W. Fischer, T. Hupfer, H. Leschke, and P. Müller, Existence of the density of states for multi-dimensional continuum Schrödinger operators with Gaussian random potentials, *Commun. Math. Phys.* **190**:133–141 (1997).
- [FK] A. Figotin and A. Klein, Localization of classical waves I: Acoustic waves, *Commun. Math. Phys.* **180**:439–482 (1996).
- [FLM] W. Fischer, H. Leschke, and P. Müller, Towards localisation by Gaussian random potentials in multi-dimensional continuous space, *Lett. Math. Phys.* **38**:343–348 (1996).
- [FMSS] J. Fröhlich, F. Martinelli, E. Scoppola, and T. Spencer, Constructive proof of localization in the Anderson tight binding model, *Commun. Math. Phys.* **101**:21–46 (1985).

- [FS] J. Fröhlich and T. Spencer, Absence of diffusion in the Anderson tight binding model for large disorder or low energy, *Commun. Math. Phys.* **88**:151–184 (1983).
- [Gra] G. M. Graf, Anderson localization and the space-time characteristic of continuum states, *J. Stat. Phys.* **75**:337–346 (1994).
- [Gri] A. G. Grin, On a condition for regularity of stationary random processes, *Theory Prob. Applications* **27**:850–855 (1982) [Russian original: *Teor. Ver. Primen.* **27**:789–795 (1982)].
- [GB] F. Germinet and S. De Bièvre, Dynamical localization for discrete and continuous random Schrödinger operators, *Commun. Math. Phys.* **194**:323–341 (1998).
- [GJ] J. Glimm and A. Jaffe, *Quantum Physics: A Functional Integral Point of View*, 2nd ed. (Springer, New York, 1987).
- [GR] I. S. Gradshteyn and I. M. Ryzhik, *Table of Integrals, Series, and Products*, corrected and enlarged edition (Academic, San Diego, 1980).
- [Ho] J. S. Howland, Perturbation theory of dense point spectra, *J. Funct. Anal.* **74**:52–80 (1987).
- [Hu] D. Hundertmark, On the time-dependent approach to Anderson localization, *Math. Nachr.* **214**:25–38 (2000).
- [HLMW] T. Hupfer, H. Leschke, P. Müller, and S. Warzel, The integrated density of states and its absolute continuity for magnetic Schrödinger operators with unbounded random potentials, e-print math-ph/0010013 (2000).
- [HS] A. M. Hinz and G. Stolz, Polynomial boundedness of eigensolutions and the spectrum of Schrödinger operators, *Math. Ann.* **294**:195–211 (1992).
- [IR] I. A. Ibragimov and Y. A. Rozanov, *Gaussian Random Processes* (Springer, New York, 1978) [Russian original: (Nauka, Moscow, 1970)].
- [Ka] O. Kallenberg, *Foundations of Modern Probability* (Springer, New York, 1997).
- [Ki1] W. Kirsch, Random Schrödinger operators: A course, in *Schrödinger Operators*, Lecture Notes in Physics, Vol. 345, H. Holden and A. Jensen, eds. (Springer, Berlin, 1989), pp. 264–370.
- [Ki2] W. Kirsch, Wegner estimates and Anderson localization for alloy-type potentials, *Math. Z.* **221**:507–512 (1996).
- [Kl1] F. Klopp, Localisation pour des opérateurs de Schrödinger aléatoires dans $L^2(\mathbb{R}^d)$: Un modèle semi-classique, *Ann. Inst. Fourier* **45**:265–316 (1995).
- [Kl2] F. Klopp, Localization for some continuous random Schrödinger operators, *Commun. Math. Phys.* **167**:553–569 (1995).
- [KL] A. Kiselev and Y. Last, Solutions, spectrum, and dynamics for Schrödinger operators on infinite domains, *Duke Math. Journal* **102**:125–150 (2000).
- [KM] W. Kirsch and F. Martinelli, On the ergodic properties of the spectrum of general random operators, *J. Reine Angew. Math.* **334**:141–156 (1982).
- [KSS1] W. Kirsch, P. Stollmann, and G. Stolz, Localization for random perturbations of periodic Schrödinger operators, *Random Operators and Stochastic Equations* **6**:241–268 (1998).
- [KSS2] W. Kirsch, P. Stollmann, and G. Stolz, Anderson localization for random Schrödinger operators with long range interactions, *Commun. Math. Phys.* **195**:495–507 (1998).
- [La] Y. Last, Quantum dynamics and decompositions of singular continuous spectra, *J. Funct. Anal.* **142**:406–445 (1996).
- [Li] M. A. Lifshits, *Gaussian Random Functions* (Kluwer, Dordrecht, 1995).
- [LGP] I. M. Lifshits, S. A. Gredeskul, and L. A. Pastur, *Introduction to the Theory of Disordered Systems* (Wiley, New York, 1988) [Russian original: (Nauka, Moscow, 1982)].

- [M] H. Matsumoto, On the integrated density of states for the Schrödinger operators with certain random electromagnetic potentials, *J. Math. Soc. Japan* **45**:197–214 (1993).
- [MH] F. Martinelli and H. Holden, On absence of diffusion near the bottom of the spectrum for a random Schrödinger operator on $L^2(\mathbb{R}^{\nu})$, *Commun. Math. Phys.* **93**:197–217 (1984).
- [MS1] F. Martinelli and E. Scoppola, Remark on the absence of absolutely continuous spectrum for d -dimensional Schrödinger operators with random potential for large disorder or low energy, *Commun. Math. Phys.* **97**:465–471 (1985). Erratum: *ibid.* **98**:579 (1985).
- [MS2] F. Martinelli and E. Scoppola, Introduction to the mathematical theory of Anderson localization, *Rivista del Nuovo Cimento* **10**(10):1–90 (1987).
- [PF] L. Pastur and A. Figotin, *Spectra of Random and Almost-Periodic Operators* (Springer, Berlin, 1992).
- [PS1] J. V. Pulé and M. Scowston, Infinite degeneracy for a Landau Hamiltonian with Poisson impurities, *J. Math. Phys.* **38**:6304–6314 (1997).
- [PS2] J. V. Pulé and M. Scowston, The spectrum of a magnetic Schrödinger operator with randomly located delta impurities, *J. Math. Phys.* **41**:2805–2825 (2000).
- [R] R. D. Richtmyer, *Principles of Advanced Mathematical Physics, Vol. I* (Springer, New York, 1978).
- [RJLS] R. del Rio, S. Jitomirskaya, Y. Last, and B. Simon, Operators with singular continuous spectrum IV: Hausdorff dimensions, rank one perturbations and localization, *J. d'Analyse Math.* **69**:153–200 (1996).
- [RS1] M. Reed and B. Simon, *Methods of Modern Mathematical Physics I: Functional Analysis, rev. and enl. ed.* (Academic, San Diego, 1980).
- [RS2] M. Reed and B. Simon, *Methods of Modern Mathematical Physics II: Fourier Analysis, Self-Adjointness* (Academic, New York, 1975).
- [Si] B. Simon, Absence of ballistic motion, *Commun. Math. Phys.* **134**:209–212 (1990).
- [Sp1] T. C. Spencer, The Schrödinger equation with a random potential: A mathematical review, in *Critical Phenomena, Random Systems, Gauge Theories, Part II*, K. Osterwalder and R. Stora, eds. (North-Holland, Amsterdam, 1986), pp. 895–943.
- [Sp2] T. Spencer, Localization for random and quasiperiodic potentials, *J. Stat. Phys.* **51**:1009–1019 (1988).
- [St] P. Stollmann, *Caught by Disorder: Lectures on Bound States in Random Media* (Birkhäuser), to appear.
- [SE] B. I. Shklovskii and A. L. Efros, *Electronic Properties of Doped Semiconductors* (Springer, Berlin, 1984) [Russian original: (Nauka, Moscow, 1979)].
- [SW] B. Simon and T. Wolff, Singular continuous spectrum under rank one perturbations and localization for random Hamiltonians, *Commun. Pure Appl. Math.* **39**:75–90 (1986).
- [U] N. Ueki, On spectra of random Schrödinger operators with magnetic fields, *Osaka J. Math.* **31**:177–187 (1994).
- [V] I. Veselić, Localisation for random perturbations of periodic Schrödinger operators with regular Floquet eigenvalues, e-print mp_arc 98-569 (1998).
- [W] Wei-Min Wang, Microlocalization, percolation, and Anderson localization for the magnetic Schrödinger operator with a random potential, *J. Funct. Anal.* **146**:1–26 (1997).
- [Y] V. Yurinsky, *Sums and Gaussian Vectors*, Lecture Notes in Mathematics, Vol. 1617 (Springer, Berlin, 1995).
- [Z] H. Zenk, Anderson localization for a multidimensional model including long range potentials and displacements, e-print mp_arc 99-450 (1999).